

MANUFACTURER DATA SHEET

Touch Screen

Manufacturer:

CTC

Model Number:

Power Station

POWERSTATION PS SERIES

User Guide

INCLUDING THE PS/PC AND THE RS/RC MODELS

***CTC Parker Automation
50 W. TechneCenter Drive, Milford, Ohio 45150***

***Phone: 513-831-2340
Technical Support: 513-248-1714***

Copyright and Trademark Notice

Copyright © 2001 by CTC Parker Automation. All rights reserved. No part of this publication may be reproduced, transmitted, transcribed, stored in a retrieval system, in any form or by any means, mechanical, photocopying, recording or otherwise, without the prior written consent of CTC Parker Automation.

While every precaution has been taken in preparing this manual, CTC Parker Automation and the author assume no responsibility for errors or omissions. Neither is any liability assumed for damages resulting from the use of the information contained herein. All product and company names are trademarks of their respective companies and licenses.

Product Warranty Information

CTC Parker Automation provides top quality products through rigid testing and the highest quality control standards. However, should a problem occur with your hardware or with the software protection key, CTC Parker's standard product warranty covers these items for 15 months from the date of shipment from CTC. Exceptions appear below:

- Backlight bulbs have a 90-day warranty.
- Third-party products, such as bus cards, carry the manufacturer's specified warranty.
- For all displays, image retention (burn-in) is not covered by warranty.
- Software revisions that occur within 60 days after purchase are available, under warranty, upon request. Please review the MachineShop License Agreement for additional software warranty information.

If you have any questions about your application or need technical assistance, please call CTC Parker's Technical Support department at 513-248-1714, 8:00 a.m. to 5:00 p.m., Eastern Time. You may call this same number after hours for emergency assistance. See *Customer Support Services on page 5* for more information about CTC Parker's support products and services.

Table of Contents

Chapter 1: Overview and Support Services.....	1
What's in this User Guide?	2
Who Should Use this Guide?.....	2
What You Should Know	2
Documentation Standards	3
Text Conventions	3
ISO Symbols.....	3
Glossary of Terms.....	4
Customer Support Services.....	5
Technical Support	5
Training and New Business Development	6
Product Support Program	7
Documentation.....	7
Chapter 2: Introducing the PowerStation PS Series	9
Hardware Overview.....	10
Software Overview	13
CPU Card	14
BIOS.....	15
Displays	17
Drives	17
Compact Flash Slots	18
Hard Drive	19
CD-ROM Drive.....	19
Floppy Drive.....	19
Drive Functions.....	21
Ports	21
Serial Ports	22
Parallel Port	25
PS/2 Ports	25
Ethernet Port.....	25

Table of Contents

Video Port.....	26
USB Ports.....	26
Power Supply.....	27
Battery.....	27
Fuse.....	27
System Peripheral Devices	28
Watchdog Timer.....	28
PowerSmart.....	28
Expansion Slots	29
I/O Addresses and IRQs	30
I/O Addresses.....	30
IRQs.....	31
Memory.....	32
Memory Modules	32
Memory Map.....	32
Memory Guidelines	33
Chapter 3: Installation	35
Selecting a Location.....	36
Class I, Division 2 Guidelines	36
Environmental Guidelines.....	36
Electrical Guidelines.....	36
Temperature Guidelines	37
Enclosure Guidelines	37
Accessing Ports, Drives, and Other Controls.....	38
Mounting the System.....	38
Mounting the PS/PC.....	38
Mounting the RS/RC	39
Connecting the RS/RC Unit to a Monitor	40
Starting the System.....	41
Starting in Windows 98 or 2000	41
Starting in Windows NT.....	41
Starting in Multiboot Systems	42
Starting in MS-DOS.....	42

Chapter 4: Maintenance and Troubleshooting	43
Exploring the BIOS Setup.....	44
Configuring Serial Ports.....	44
Resetting Disk Boot Priority	44
Adjusting Brightness and Contrast	45
Loading Default BIOS Settings	45
Reinstalling Software.....	46
Reinstalling Software on Systems Running Windows	46
Reinstalling PowerStation Software on Systems Running MS-DOS	57
Restoring a Compact Flash Card.....	59
Maintaining the Display on a PS/PC	60
Cleaning the Display Screen.....	60
Reconfiguring the Touchscreen Driver	60
Recalibrating the Touchscreen	62
Performing Internal Maintenance.....	65
Replacing Components	65
Observing ESD Precautions	65
Opening and Closing the System.....	66
Adding Expansion Cards	69
Changing Jumper Settings	71
Troubleshooting	75
Problems When Starting.....	75
Problems Signaled by PowerSmart.....	81
Problems with Displays	83
Problems with Touchscreens.....	84
Problems with Peripheral Devices.....	85
Appendix A: Specifications	87
Physical Specifications.....	88
Recommended SDRAM Manufacturers.....	91
Operating Systems Supported.....	91
Display Specifications	92
Environmental Specifications.....	93
Electrical Specifications.....	94

Testing Specifications	94
Faceplate Chemical Resistance	95
Agency Approvals	96
Appendix B: Dimensional Drawings	97
Model: PS10-2/PC10-2	98
Front View: Monitor	98
Left Side View: Components.....	99
Back View: Components.....	100
Cutout.....	101
Model: PS12-2/PC12-2	102
Front View: Monitor	102
Left Side View: Components.....	103
Back View: Components.....	104
Cutout.....	105
Model: PS15-2/PC15-2	106
Front View: Monitor	106
Left Side View: Components.....	107
Back View: Components.....	108
Cutout.....	109
Model: PS10-3/PC10-3 Model: PS10-4/PC10-4.....	110
Front View: Monitor	110
Left Side View: Components.....	111
Back View: Components.....	112
Cutout.....	113
Model: PS12-3/PC12-3 Model: PS12-4/PC12-4.....	114
Front View: Monitor	114
Left Side View: Components.....	115
Back View: Components.....	116
Cutout.....	117
Model: PS15-3/PC15-3 Model: PS15-4/PC15-4.....	118
Front View: Monitor	118
Left Side View: Components.....	119
Back View: Components.....	120
Cutout.....	121

Model: RS00-2/RC00-2	122
Left Side View: Components.....	122
Back View: Components.....	123
Cutout.....	124
Model: RS00-3/RC00-3 Model: RS00-4/RC00-4	125
Left Side View: Components.....	125
Back View: Components.....	126
Cutout.....	127
Index	129

CHAPTER 1: OVERVIEW AND SUPPORT SERVICES

This chapter explains what is in this User Guide and who should use the Guide. It also describes the documentation standards used in the Guide and important CTC customer support services.

Chapter Contents

- What's in this User Guide?* 2
- Who Should Use this Guide?*..... 2
- What You Should Know* 2
- Documentation Standards*..... 3
- Customer Support Services*..... 5
- Documentation*..... 7

What's in this User Guide?

This Guide describes the following CTC PowerStations and industrial PCs. Unless otherwise indicated, the information in this Guide applies to all of the computers listed below.

PowerStations	Industrial PCs
PS	PC
RS*	RC*

* = No display

The purpose of this Guide is to help you set up and use your PowerStation model PS, PC, RS, or RC. It describes your system and explains how to install your system, how to maintain it in good condition, and how to solve common operating problems. In the Guide, you'll find the following chapters:

Chapter	Title	Contents
1	<i>Overview and Support Services</i>	Overview of this Guide's contents, who should use it, and CTC customer support services.
2	<i>Introducing the PS Series</i>	System functions and features, including cabling, pinout, and addressing information.
3	<i>Installation</i>	How to mount your system in an enclosure or on a panel and start it up.
4	<i>Maintenance and Troubleshooting</i>	How to maintain the system and solve operation problems.
Appendix A	<i>Specifications</i>	Tables showing complete system specifications.
Appendix B	<i>Dimensional Drawings (including cutout and mounting diagrams)</i>	Complete dimensional drawings for all systems described in this Guide.

Who Should Use this Guide?

This Guide is designed for factory automation and control engineers, or technicians who use or service industrial computers.

What You Should Know

In order to use this Guide most effectively, you should be familiar with the basic operations and uses of industrial computers and with the DOS or Windows operating system used on your computer.



Documentation Standards

This Guide uses the following standards.

Text Conventions

Style	Type of Text
Bold	Names of buttons, tabs, menus, menu items, commands, files, and other important terms.
<i>Italics</i>	Titles of User Guides, chapters, or sections, and linked cross references.
Title Case	Names of keyboard keys, dialog boxes, directories, and folders.
Courier font	Text to be entered from a keyboard.
▶	Next step in a software path. For example, “In the Windows task bar, click Start ▶ Settings ▶ Control Panel. ”
+	Indicates two or more keyboard keys that must be pressed simultaneously. For example, Control+Alt+Delete.
Note	Alternative approaches or issues to be aware of.
Important	Information that will save time and minimize problems.
Warning	Information that will prevent equipment damage or personal injury.

ISO Symbols

Symbol	Meaning
	International Standards Organization (ISO) symbol for Caution (ISO 3864 No. B.3.1). Denotes activity that could affect operation of the computer if instructions are not followed.
	ISO symbol for Caution—risk of electrical shock (ISO 3864 No B.3.6). Denotes activity that could cause personal injury from electrical shock or damage to equipment if instructions are not followed.

Glossary of Terms

The following special terms are used in this guide.

Term	Definition
Development system	System on which you develop machine control projects and applications
Driver	Software program that links a peripheral device to your operating system—e.g., a CD-ROM driver, network driver, or touchscreen driver
FlashBack	CTC software utility for restoring the operating system and MachineShop files to a Compact Flash card
HMI	Human-machine interface
Interact	CTC's HMI development and runtime software
MachineLogic	CTC's PC-based automation control software
MachineShop	CTC's integrated development software for both Interact and MachineLogic
MachineShop Shell	User interface screen for MachineShop software
Online help	Software documentation that is available on-screen from within a software program. MachineShop, Interact, MachineLogic, and Interact and MachineLogic device drivers all have online help available.
PowerStation	CTC industrial computer bundled with MachineShop, Interact, and MachineLogic software
PowerSmart	CTC's software utility for monitoring computer functions (such as internal temperature, power supply output voltage, and hours of operation) and reporting problems
RS, RC	Remote system—No display
Runtime system	System on which machine control applications run
Touchscreen	Touch-sensitive display screen on which you press in order to send commands to the software
User Guide	Manual for using your computer or software product

Customer Support Services

We welcome your thoughts and suggestions about our products and services. Please contact us by telephone, email, or fax. You also can visit CTC Parker on the Web to learn the latest about our hardware, software, and customer support services.

Telephone	513-831-2340
Technical Support	513-248-1714
Fax	513-831-5042
E-mail	sales@ctcusa.com
	support@ctcusa.com
	DocComments@ctcusa.com
World Wide Web	www.ctcusa.com

We recognize that every customer and every application have different support needs, so we offer four types of customer support services:

- Technical Support
- Training and New Business Development
- Product Support Program
- Documentation

Technical Support

The Technical Support department welcomes your questions as you develop or run your applications. We offer complimentary support for any customer, whether you are an end-user, original equipment manufacturer (OEM), system integrator, or distributor.

If you have a question about your system, be sure to first:

1. Check any release notes shipped with the system.
2. Consult the documentation and other printed materials shipped with your system.
3. Review Chapter 4, *Maintenance and Troubleshooting*, in this Guide.

If you cannot find a solution using one of the preceding sources:

4. Call your CTC products distributor for support.
5. View the Technical Support web page at www.ctcusa.com. You'll find answers to Frequently Asked Questions, application notes, product user guides, and software downloads that may be helpful.
6. Call CTC Technical Support at 513-248-1714, 8:00 a.m. to 5:00 p.m., Eastern Time.

You can call this same number after hours for emergency assistance.

Training and New Business Development

Our Training and New Business Development department provides service in two areas: training and consulting.

Training

We offer training on all of our products, either at CTC Parker, in our state-of-the-art training center, or at your site. You can learn how to:

- Write custom interfaces
- Develop specialized applications
- Implement your complete operator interface application

To contact the Training Coordinator:

Telephone	1-800-233-3329
E-mail	training@ctcusa.com

Application Engineering Services

We offer consulting services through our Application Engineering Services group. Our Application Engineering group can build your application from the ground up:

- Write custom communications drivers
- Design special modules to perform functions unique to your application

Our specialists are flexible, so they can create a project development schedule that meets your needs. You can contact Application Engineering Services in one of the following ways:

Telephone	1-800-233-3329
E-mail	appeng@ctcusa.com

Product Support Program

The Product Support Program (PSP) is designed to keep you up-to-date with the current versions of CTC Parker software. It's an easy, cost-effective way to receive the most recent CTC software and associated utilities. The PSP consists of a renewable, one-year membership that provides you with the following:

- Free upgrades and utilities
- E-mail notification of software updates
- Valuable tools for MachineShop, Interact, and MachineLogic

Single-user, multi-user, and corporate licenses are available. To learn more about PSP, contact us:

Telephone	1-800-233-3329
E-mail	sales@ctcusa.com

Documentation

You can download CTC product documentation from our Web site at www.ctcusa.com. Click **Support** and then **Product Manuals**.

We also welcome your comments on this User Guide or any of our other documentation. Please e-mail your comments to mail to: DocComments@ctcusa.com

CHAPTER 2: INTRODUCING THE POWERSTATION PS SERIES

This chapter describes the features of the PowerStation PS Series including the display options, drives, and ports that link the system with other devices. It also describes system peripheral devices and the systems' expansion slots, I/O addresses, and memory.

Chapter Contents

<i>Hardware Overview</i>	10
<i>Software Overview</i>	13
<i>CPU Card</i>	14
<i>BIOS</i>	15
<i>Displays</i>	17
<i>Drives</i>	17
<i>Ports</i>	21
<i>Power Supply</i>	27
<i>System Peripheral Devices</i>	28
<i>Expansion Slots</i>	29
<i>I/O Addresses and IRQs</i>	30
<i>Memory</i>	32

Hardware Overview

The PowerStation PS Series includes models PS/PC which come with a display and models RS and RC which are remote systems.

Note For complete specifications on all systems, see *Appendix A: Specifications on page 87*.

All of the systems have the following features:

- Internal and external Compact Flash (CF) slots
- Optional hard disk, CD-ROM, and floppy disk drives
- Three external serial ports (COM1, COM2, COM3)
- Parallel port
- Ethernet port
- Video port
- Two PS/2 ports (for keyboard and mouse)
- Two USB ports
- Watchdog timer
- PowerSmart system monitor

Differences among the systems are in the following features:

- Touchscreen (remote systems do not have one)
- Sizes and types of displays used
- Types and quantity of expansion slots provided

Note For additional information about these systems and their displays, see the following: *Display Specifications on page 92*, and *Physical Specifications on page 88*.

The basic PowerStation models discussed in this guide include the PS, PC, RS, and RC. The following illustrations represent the difference between the models that operate with PC/104 cards (PSXX-2, PCXX-2, RSOO-2) and models that operate with ISA and PCI cards (PSXX-3, -4; PCXX-3, -4; and RSOO-3, and -4). The following illustrations do not reflect monitor size. Monitor's are available in 10", 12", and 15" on the PS and PC models only.

Software Overview

Each PowerStation is pre-loaded with the software you have purchased. Backup copies of all installed software are provided on CDs and floppy disks in case you need to reinstall any of it.

The following table shows the software you will receive with your system. Descriptions of the software follow the table.

CD/Disk Name and Part Number	PS/RS				PC/RC		
	DOS	Windows			Windows		
		98	2000	NT	98	2000	NT
Industrial PC Drivers and Utilities CD DCD-1000		X	X	X	X	X	X
Windows 2000 Emergency Recovery Disk KA-73133-100			X			X	
Win NT 4.0 Emergency Recovery Disk KA-72668-100				X			X
MS-DOS 6.22 and Utilities Installation Disk KA-72953	X	X		X			
PowerStation Start Disk SA-83109-105	X	X		X			
MachineShop Installation CD KA-83103	X	X		X			

- Industrial PC Drivers and Utilities CD DCD-1000: Contains system files, utilities, and most device drivers for the PCs as well as the manual and AutoCAD files.
- Windows 2000 Emergency Recovery Disk KA-73133-100: Contains files to start Windows 2000 if the operating system is damaged. Shipped only with PCs running Windows 2000.
- Win NT 4.0 Emergency Recovery Disk KA-72668-100: Contains files to start Windows NT 4.0 if the operating system is damaged. Shipped only with PCs running Windows NT 4.0.
- MS-DOS 6.22 and Utilities Installation Disk KA-72953: Contains the MS-DOS operating system and utilities.
- PowerStation Start Disk SA-83109-105: Contains PowerStation utilities and drivers.
- MachineShop Installation CD KA-83103: Contains files for the MachineShop Shell, MachineShop Toolbar, Interact, and touchscreen and network drivers.

CPU Card

The CPU card in the PS/PC and RS/RC models uses a custom, small format form-factor. The CPU card has the following characteristics.

Feature	Description
Size (H x W)	8.0" (203.2mm) x 10.65" (270.5mm)
Processor	Intel® Pentium MMX™ 166 or 266MHz
Bus interfaces	<ul style="list-style-type: none">• ISA bus: 16-bit, 8MHz• PCI bus: 32-bit, 33MHz
Configurable jumpers	<ul style="list-style-type: none">• COM2• Ethernet port• CF master/slave (jumpers for internal and external CF)• CMOS jumper

The following illustration shows the CPU card and its important features.

CPU Card

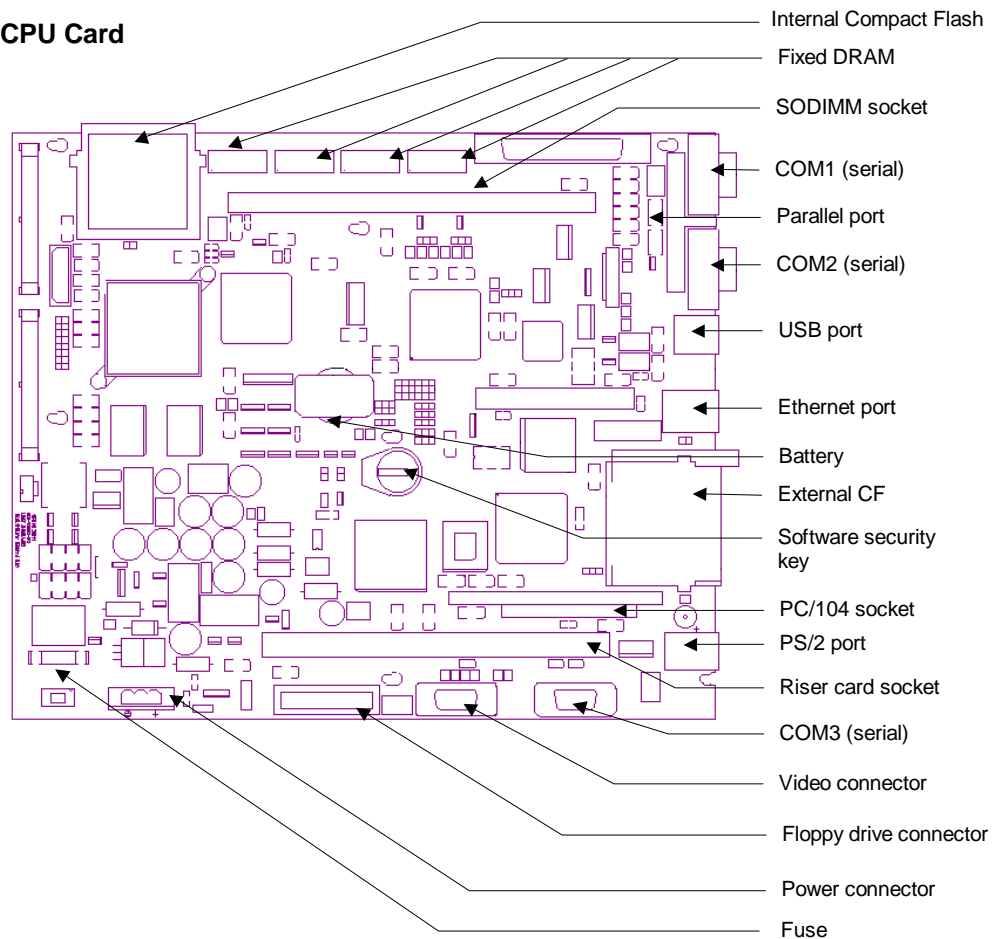

Note To see the locations of the PowerStation PS Series' configurable jumpers, see *Jumper locations* on page 71.

BIOS

The PowerStation PS Series uses a Phoenix Basic Input Output System (BIOS), with 256K FLASH memory. The system BIOS performs two functions:

- It performs initialization tasks (testing and configuration of the system's standard components—e.g., video, system board RAM, floppy and fixed disks, serial and parallel ports, and other I/O devices) during its Power-on Self Test (POST).
- It provides application programs with a hardware-dependent software interface to system devices.

Standard BIOS features include the following:

- FLASH/EPROM-based setup utility
- POST
- Password protection
- System plug and play support
- Advanced power management

In addition, the system BIOS provides the following features:

- A **Load Setup Defaults** feature is provided so that you can re-establish the BIOS default settings if necessary.
- You can select I/O resources for the serial ports, touchscreen, and parallel port through menus in the BIOS CMOS setup.
- The video BIOS supports Video Electronics Standards Association (VESA) video modes.
- Jumpers select video BIOS support for each supported flat panel display, as well as for a CRT-only mode. These jumpers connect to I/O pins on the video controller, and the BIOS reads these connections at startup.
- When configured for flat panel displays, the BIOS provides analog video support simultaneously. When configured for CRT-only, the BIOS supports an analog multi-scan monitor.
- The BIOS supports the following flat panel types.

1024 x 768 color TFT
800 x 600 color TFT
640 x 480 color TFT
640 x 480 monochrome STN

- You can control flat panel brightness through menus in the BIOS CMOS setup.
- The BIOS supports a startup “splash screen” that displays the CTC Parker logo. You can enable or disable this screen through a menu selection in the CMOS setup.

Note For additional information about the system BIOS, see *Physical Specifications on page 88*.

Displays

The PS/PC models support the displays shown in the table on the following page.

PowerStation/PC	Size	Resolution	Color	Type
PS	9.5"	VGA	Mono	STN
	10.4"	VGA	Color	TFT
	12.1"	SVGA	Color	TFT
	15.1"	XGA	Color	TFT
PC	10.4"	VGA	Color	TFT
	12.1"	SVGA	Color	TFT
	15.1"	XGA	Color	TFT

Note PS's with 12.1" and 15.1" displays have a special card installed that enables them to display Interact screens at 640 x 480 VGA resolution. See also *Display Specifications on page 92*.

Drives

The PowerStation PS Series is equipped with a variety of storage and read/write devices:

- External Compact Flash (CF) slot
- Internal Compact Flash slot
- Hard disk drive (optional)
- CD-ROM drive (optional)
- External 3.5" floppy disk drive (optional)

These drives are described in this section, and, except for the hard drive and internal CF, their locations are illustrated on a PowerStation Model PS.

Compact Flash Slots

The PowerStation PS Series has two slots to accommodate CF cards: one external and one internal. Both slots support Type 1 or Type 2 CF cards, and IBM's Microdrive.

- The internal CF is located in the upper left corner of the CPU card (see the CPU card illustration on page 15). The internal CF is the primary (master) drive when no hard drive is installed and a secondary (slave) drive when a hard drive is installed.
- The external CF is located at the left side of the unit, as shown in the following illustration. The external CF is the primary (master) drive when no hard drive is installed and the internal CF is not being used. It is a secondary (slave) drive when a hard drive is installed or the internal CF is being used.

Note CF cards are optional with the PC and the RC models.

CF Slot and CD-ROM Drive on a PSXX-2

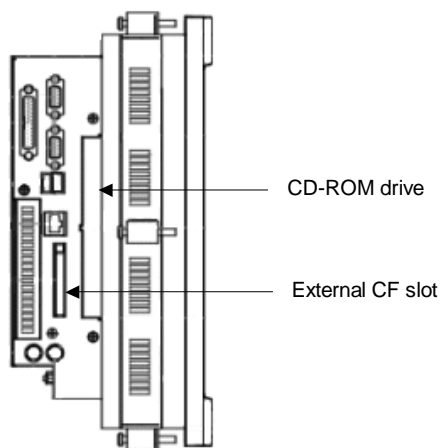

Using CF cards

A CF card is like a removable hard drive and provides non-volatile storage memory. A CF card is often used as a supplement to, or a replacement for, a hard drive because a CF card is well suited to environments in which the unit may be vibrated or shaken.

Note You also can use a hard drive with no CF at all.

- You can use a CF card as the startup drive or as a secondary IDE drive.
- You can reformat a CF card or update the files on it. See *Restoring a Compact Flash Card on page 59* for complete instructions.

Uses for the CF card are as follows: Internal CF	External CF
Operating system	Programs
Development and runtime software	Projects and applications
May use with hard drive	May use with hard drive

If you purchased a CF card, we recommend that you purchase at least one additional card to serve as a backup. You may wish to have several cards on hand to store different projects. To purchase additional CF cards, call our Customer Service department at 513-248-2340.

Removing and replacing CF cards

To remove and replace an external CF card, complete the following steps:



1. Turn off the system.

Warning Always make sure that the system is turned off when inserting or removing a CF card.

2. Press the eject button next to the external CF slot, and remove the card by sliding it out of its slot toward you.
3. Reinstall the CF card by carefully inserting it into its slot and pushing it into the slot until the card is securely seated (the eject button should pop out).



Important When inserting a CF card, align the arrow on the card with the arrow that appears over the CF slot.

Hard Drive

The PowerStation PS Series has an optional internal hard disk drive for storing system software, projects, and applications.

CD-ROM Drive

An optional 24X CD-ROM drive is located on the left side of the unit (see the illustration on page 18). The CD-ROM drive can be used to read files or load and run software.

Floppy Drive

The PowerStation PS Series has an optional, external, 3.5", 1.44MB floppy drive, which can be mounted on a panel or desktop, or fastened to the back of the unit as shown in the following illustration on the back of a unit. You can attach the floppy drive to its own connector at the back of the PowerStation PS.

Floppy Drive

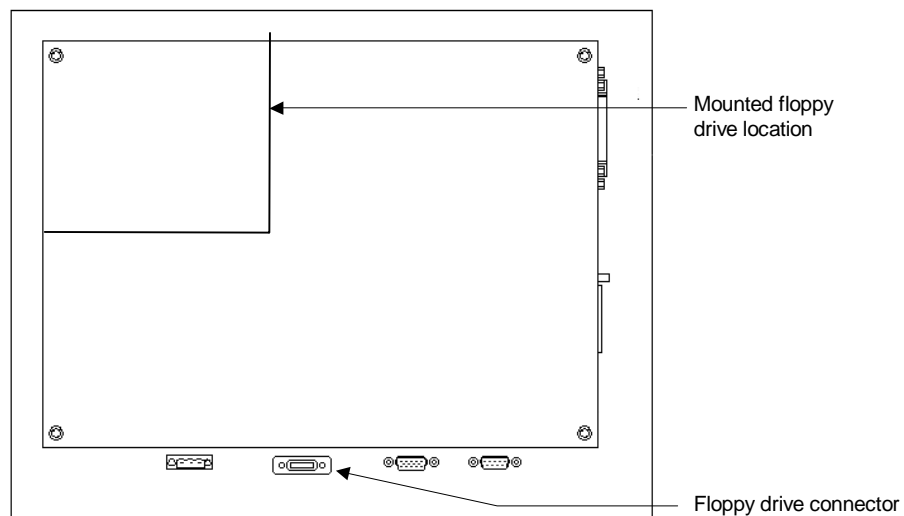

You can purchase a floppy drive connector from CTC Parker Automation. But if you need to make a cable to connect the floppy drive to the PowerStation PS, the pinout information for the floppy drive connector is shown in the following table.

Pin #	Signal Name	Pin #	Signal Name
1	+5VDC	14	WRDATA#
2	INDX#	15	GND
3	+5VDC	16	WE#
4	DENSEL	17	GND
5	+5VDC	18	TRKO#
6	FDMEO#	19	GND
7	GND	20	WP#
8	FDSO#	21	GND
9	GND	22	RDDATA#
10	DIR#	23	GND
11	GND	24	HDSEL#
12	STEP#	25	GND
13	GND	26	DSKCHG#

Drive Functions

The following table summarizes functions of the drives on the PowerStation PS Series.

Note Letters used to define the drives (A, C, D, etc.) will depend upon which drives are installed on your system.

Drive Type	Size	Use
Internal Compact Flash (CF) card	8, 16, 32, 48, 96, or 128MB	Primary (master) drive when no hard drive is installed; secondary (slave) drive when a hard drive is installed. May store the operating system, and development and runtime software. Download files to this drive only if its size is sufficient.
External Compact Flash (CF) card	8, 16, 32, 48, 96, or 128MB	Primary (master) drive when no hard drive is installed and the internal CF is not being used. Secondary (slave) drive when a hard drive is installed or the internal CF is being used. May store projects and applications. Download files to this drive only if its size is sufficient.
3.5" Floppy drive (optional, external)	1.44MB	May be used to install software or save files. Use it to download projects to the unit and back up files.
Hard drive (optional)	3.2GB or higher.	Primary (master) drive when installed. Stores the operating system, development and runtime software, projects, and applications.
CD-ROM drive (optional)		May be used to install operating systems or other software.

Ports

The PowerStation PS Series has the following ports:

- Three 16C550-compatible external serial ports
- One standard parallel port, supports Standard Parallel Port (SPP), Enhanced Parallel Port (EPP), and Enhanced Capability Port (ECP) standards
- Two PS/2 ports (one each for mouse and keyboard)
- One 10/100 Base-T Ethernet port
- One analog video port
- Two USB ports.

The following illustrations show the location of these ports; the sections that follow explain the ports' uses and give pinout information.

Note The image on the following page is an illustration of a PXXX-2 model. However, the ports are located in the same spot on all models.

Ports: Side View

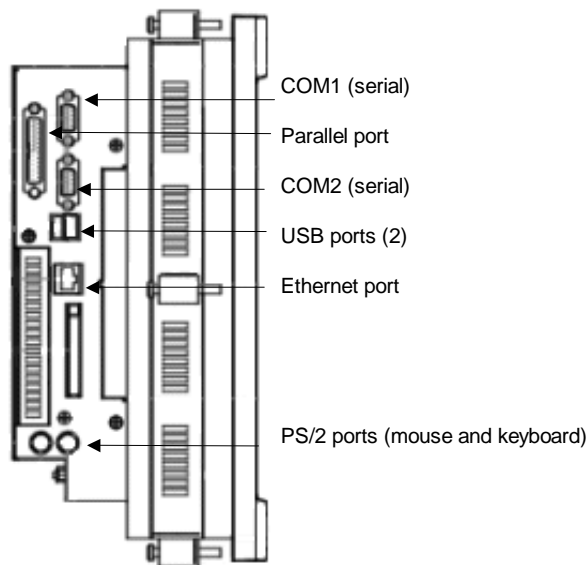

Ports: Back View

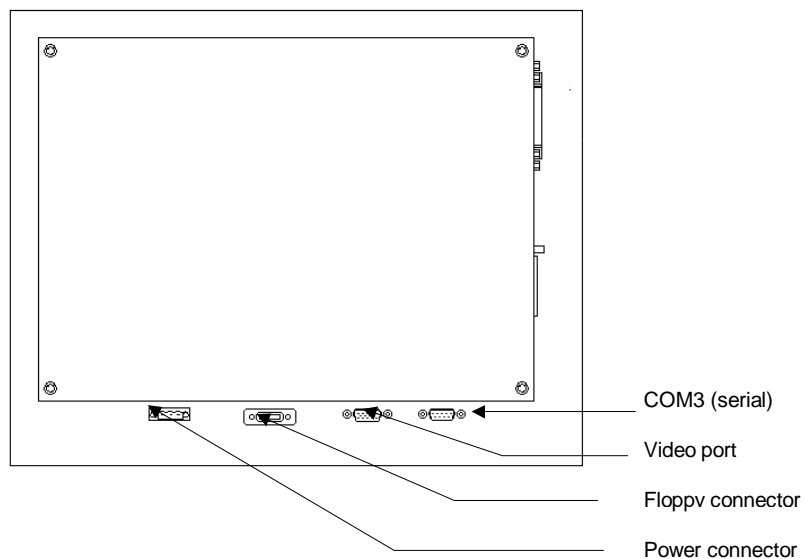

Serial Ports

As the preceding illustrations show, the PowerStation PS Series has three external serial ports:

- These ports are identified as COM1, COM2, and COM3.
- COM1 and COM2 are located on the left side of the unit; COM3 is located at the back of the unit.
- All three ports use standard, 9-pin, Male, D-sub connectors.

Communication standards for these ports are shown in the following table.

Port	Communication Protocol
COM1 COM3	<ul style="list-style-type: none"> RS-232
COM2	<ul style="list-style-type: none"> Default protocol (as shipped) is RS-485 Configurable for RS-232, RS-422, and RS-485

Note The system's touchscreen connector, located on the CPU card, is an internal serial controller designated as COM4.

When configuring COM2 for connection with a programmable logic controller (PLC), the communication standard you select for COM2 depends upon the distance between the system and the controller, as well as the communication standards that the controller supports:

- If you are using RS-232 communications, the length of the serial cable should not exceed 50 feet (15 meters).
- RS-422 and RS-485 communications offer greater noise immunity than RS-232 and increase the maximum cable length to 4,000 feet (1,200 meters).
- RS-422 communications are full-duplex (can send and receive simultaneously).
- RS-485 communications are half-duplex (can only send or receive at one time).

For information on the specific connections required for Interact or MachineLogic drivers, look in the Help file associated with the driver.

For instructions on how to reconfigure COM2 for the RS-232, RS-422, or RS-485 protocol, see *COM2 communication protocol on page 72*.

COM1, 2, and 3 pinouts

If you need to make a cable for communicating with COM1, COM2, or COM3, the pinout and signal information for these ports is shown below.

Note Remember, COM2 is configurable for RS-232, RS-422, and RS-485; its default setting is RS-485.

Pin #	RS 232 (COM1, 3 default)	RS-422	RS-485 (COM2 default)
1	DCD, data carrier detect	TX-, transmitted data -	TX-, transmitted data -
2	RX, received data	TX+, transmitted data +	TX+, transmitted data +
3	TX, transmitted data	RX+, received data +	RX+, received data +
4	DTR, data terminal ready	RX-, received data -	RX-, received data -

Pin #	RS 232 (COM1, 3 default)	RS-422	RS-485 (COM2 default)
5	GND, signal ground	GND, signal ground	GND, signal ground
6	DSR, data set ready	DSR, data set ready	DSR, data set ready
7	RTS, request to send	RTS, request to send	RTS, request to send
8	CTS, clear to send	CTS, clear to send	CTS, clear to send
9	RI, ring indicator	RI, ring indicator	RI, ring indicator

The following illustration shows the cable diagrams for the RS-232, RS-422, and RS-485 protocols.

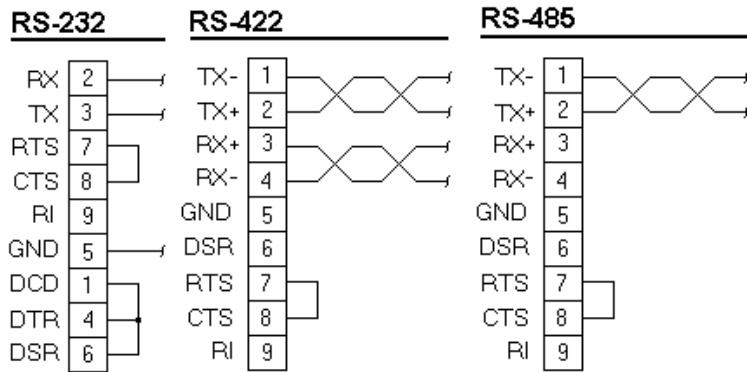

Connecting to a PC

If you want to transfer files via serial connection from another PC to a PowerStation PS Series model, connect a serial cable with a null modem between available serial ports on each system. If you need to construct your own cables, refer to the following diagrams.

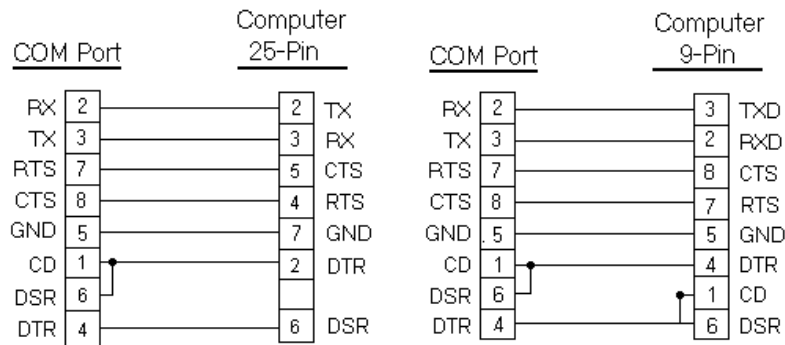

[download](#)



Important Be careful not to connect any wires to unused connector pins.

Parallel Port

All models in the PowerStation PS Series has one parallel port, located on the left side of the unit (see the illustration on page 22).

Pinout data for the parallel port is shown below.

Pin #	Signal Name	Pin #	Signal Name
1	STB (- Strobe)	10	ACK (- Acknowledge)
2	PD0 (+ Data Bit 0)	11	BUSY (+ Busy)
3	PD1 (+ Data Bit1)	12	PE (+ Paper End)
4	PD2 (+ Data Bit 2)	13	SLCT (+ Select)
5	PD3 (+ Data Bit 3)	14	AFD (- Auto Feed)
6	PD4 (+ Data Bit 4)	15	ERR (- Error)
7	PD5 (+ Data Bit 5)	16	INIT (- Initialize Printer)
8	PD6 (+ Data Bit 6)	17	SLIN (- Select Input)
9	PD7 (+ Data Bit 7)	18-25	GND (Ground)

The PowerStation PS Series can interface with any parallel printer designed for use with PCs. Connect a printer to the parallel port, using a standard PC parallel cable.

PS/2 Ports

All models in the PowerStation PS Series has two PS/2 ports located at the left side of the unit (see the illustration on page 22)—one to connect a keyboard to the system and the other to connect a mouse. Pinout data for these ports is shown below.

Pin	Signal Name	Pin	Signal Name
1	Data	4	+5V (Fused)
2	NC	5	Clock
3	GND	6	NC

Ethernet Port

The PowerStation PS Series has an Ethernet RJ-45 port that allows you to connect the unit to a local area network (LAN) (see the illustration on page 22).

- This port uses an Intel 82559 10/100 Mbps PCI Fast Ethernet controller with an integrated IEEE 802.3 10Base-T and 100Base-TX interface.

Pinout data for this port is shown below. For setup options, consult the manual that came with your network software.

Pin#	Signal	Pin#	Signal
1	TX+	5	75 Ohm Terminator
2	TX-	6	RX-
3	RX+	7	75 Ohm Terminator
4	75 Ohm Terminator	8	75 Ohm Terminator

Video Port

All models in the PowerStation PS Series has a dedicated video port located at the back of the unit (see the illustration on page 22).

- The video port has 2MB of embedded video memory, arranged in a 64-bit configuration.
- The system's video output will support monochrome and high resolution color displays.

Note For complete display specifications, see *Display Specifications on page 92*.

Pinout data for this port is shown below. For setup options, consult the manual that came with your network software.

Pin	Signal Name	Pin	Signal Name
1	ROUT	10	GND
2	GOUT	11	NC
3	BOUT	12	DDC data
4	NC	13	H_SYNC
5-8	GND	14	V_SYNC
9	+5v (FUSED)	15	DDC Clock

USB Ports

The PowerStation PS Series has two external USB ports located at the left side of the unit (see the illustration on page 22).

- Each port can support one peripheral device.
- If you want to connect more than two USB devices, connect an external hub to either port in order to ensure that all devices receive an adequate signal.
- Self-identifying peripherals can be plugged in while the system is running.
- The system has automatic mapping of function to driver and configuration. Pinout data for the two USB ports is shown in the following table.

Pin #	Signal Name
1	Vcc
2	-Data
3	+Data
4	GND

Power Supply

The PowerStation PS Series is powered by 24VDC @ 3.25A. The input voltage range is 18VDC-28VDC. All system voltages, such as +/-5V, +/-12V, 3.3V, and CPU voltages are generated on the CPU card from the 24VDC input voltage.

The power supply is designed to protect against:

- Misapplication of 120VAC to the DC input connector
- Damage caused by reverse polarity DC input connections

In either case, the extent of damage to the electronics would be limited to blowing the input fuse.

For information about the fuse, see *Fuse* below. For more information about the PowerStation PS Series power supply, see *Testing Specifications on page 94*.

Battery

The PowerStation PS Series uses a 3.0V, socket battery for real-time clock backup and CMOS storage. The battery is located on the CPU card (see the illustration on page 15) and is replaceable with a standard CR2032 battery.



CAUTION for units with replaceable Lithium batteries

- There is danger of explosion if the battery is incorrectly replaced.
- Replace the battery only with the same type of battery or an equivalent type recommended by the manufacturer.
- Dispose of used batteries according to the manufacturer's instructions.

Fuse

The PowerStation PS Series has a 5A fuse located on the CPU card (see the illustration on page 15). The fuse is a 250VAC Littelfuse, part #216.315. It is field replaceable by the same model fuse or its equivalent.

System Peripheral Devices

System peripheral devices in the PowerStation PS Series include the watchdog timer and the PowerSmart system monitor.

Watchdog Timer

The PowerStation PS Series' CPU card supports a watchdog timer. If the processor does not read or write to the timer register within 1.6 seconds, the timer will reset the computer.

The watchdog timer is configurable within CTC's Interact software. If you are an Interact user and want to learn how to configure the watchdog timer, open the Interact Application Manager online help, and look in *Application Settings*.

PowerSmart

The PowerStation PS Series comes with a PowerSmart system monitor that continuously monitors the following on a system:

- Five internal power supply voltages
- Internal temperature
- Total hours that the system has been in operation
- Communication errors in system monitoring devices

Note The Internal Temperatures window displays temperature data for the last 24 hours. If you want to see more precise temperature and time readings, use a mouse to move the small, white zoom arrows in the window.

On systems running Windows 98, 2000, XP, or NT 4.0 PowerSmart appears as a graphical display, shown in the following illustration. Activate this display by clicking the PowerSmart icon on the Windows desktop.

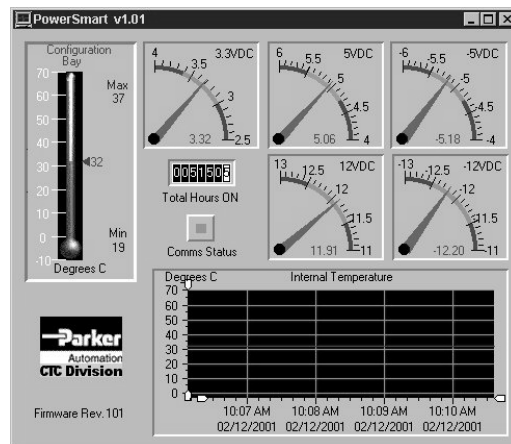

On systems running MS-DOS, you can access a text-based version of this display by typing **Pwrsmrt.exe** at the DOS prompt and then pressing **Return**.

Under Windows, MS-DOS, or NT, PowerSmart continually monitors the system regardless of whether the displays are shown.

If any system parameters are out-of-limit:

- The PowerSmart display will change color, and the gauges will show the error condition.
- If the display has been minimized, the PowerSmart button on the Windows taskbar will flash continually. Click on the button to show the display.

If communication errors occur in system monitoring devices:

- The **Comms Status** light (left of center in the display) will change from green to red.
- A dialog box will appear describing the problem.

See *Problems Signaled by PowerSmart on page 81* for suggestions about how to respond to error conditions.

To perform its functions, PowerSmart uses the I2C devices shown below. All devices are connected on a two-wire SMBus.

PowerSmart I2C Device	Location	Function
MicroController (87LPC764)	CPU card U38	Programs and monitors all other peripheral devices on the bus. Determines the presence of error conditions. Logs error counts, temperature extremes, and hours of operation. Communicates error and status information to the SMBus host interface.
Peripheral monitor (DS1780)	CPU card U41	Monitors power supply voltages and temperature.
EEPROM (24C02)	CPU card U39	Stores error counts, temperature extremes, operation hours, and system configuration information.

Expansion Slots

The maximum depth for all expansion slots is 11". The PSXX-2 (also PCXX-2, RSXX-2 and RCXX-2 models) can accommodate up to three PC/104 expansion cards through the PC/104 socket on the CPU card (for the location of this socket, see the illustration on page 15).

The PSXX-3 (also the PC, RS, RC) offers ISA and PCI expansion options with an ISA majority.

The PSXX-4 (also PC, RS, and RC) offers PCI and ISA expansion options with a PCI majority.

Both the PSXX-3 and PSXX-4 models use a riser card that attaches to the CPU card (for the riser card socket location, see the illustration on page 15). Hold down brackets are available for the ISA and PCI cards to prevent the expansion cards from moving in environments where vibration occurs. Expansion options for both systems are shown in the following table:

Model	Expansion Slots
PS/PC/RS/RCXX-2	<ul style="list-style-type: none"> • Three PC/104
PS/PC/RS/RCXX-3	<ul style="list-style-type: none"> • Three 16-bit ISA <i>or</i> • Two 16-bit ISA and one PCI
PS/PC/RS/RCXX-4	<ul style="list-style-type: none"> • Three 32-bit PCI <i>or</i> • Two 32-bit PCI and one 16-bit ISA

I/O Addresses and IRQs

This section describes the I/O addresses and IRQs used by the PowerStation PS Series.

I/O Addresses

The following table shows the I/O addresses used by the PowerStation PS Series. Make sure that any adapter cards you install do not conflict with these addresses.

Address	Function
0000-000F	DMA controller 1
0020-0021	Interrupt controller 1
0040-0043	Counter timer 1
0048-004B	Counter timer 2
0060/0062	Keyboard, NMI, speaker
0061/0063	Watchdog timer
0070-0071	Real time clock/NMI mask
0080-008F	DMA page register, POST checkpoint
00A0-00A1	Interrupt Controller 2
00C0-00DE	DMA Controller 2
00F0-00FF	Numeric co-processor
0170-0177	Secondary IDE channel
01F0-01F7	Primary IDE channel
0278-02FF	Parallel port 2 (CTC software security key)
02E8-02EF	Serial port 4 (default)
02F8-02FF	Serial port 2 (default)
0376	Secondary IDE port
0377	Floppy channel 2 command
0377 bit 7	Floppy disk change, channel 2
0377 bit 0:6	Secondary IDE channel status port

Address	Function
0378-037F	Parallel port 1 (default)
03BC-03BF	Parallel port 3 (opt)
03E8-03EF	Serial port 3 (default)
03F0-03F5	Floppy channel
03F6-03F7	Primary IDE and floppy
03F8-03FF	Serial port 1 (default)
04D0-04D1	Edge/level interrupts
0CF8-0CFF	PCI configuration

IRQs

The PowerStation PS Series configures IRQs as shown below.

IRQ	Default	Option
NMI	Parity/System errors	
0	System timer	
1	Keyboard	
2	Cascade for IRQ 8-15	
3	COM2	COM4
4	COM1	COM3
5	Reserved for user	
6	Floppy controller	
7	Parallel port 1	Available
8	Real-time clock	
9	COM3	COM4
10	Reserved for user	
11	COM4	COM3
12	Reserved/PS/2 mouse	
13	Co-processor	
14	Primary IDE	
15	Reserved	Secondary IDE

If you choose to change IRQ settings, keep the following in mind:

- Any IRQ designated as “Reserved for user” can be taken by the PCI Ethernet adapter, which is a plug and play device.

- To see which IRQ the Ethernet adapter is using in systems running under Windows,
 - Click **Start** on the Windows taskbar.
 - Then click **Control Panel ► System ► Device Manager ► Network Adapters ► PCI Adapter ► Properties**.

Memory

This section describes the SDRAM available in the PowerStation PS Series, the way in which the PowerStation PS Series allocates memory, and memory guidelines for Interact software users.

Memory Modules

The PowerStation PS Series comes with 32MB of SDRAM soldered onto the CPU card in four 8MB chips. In addition, a single socket on the CPU card can accommodate up to 256MB of SDRAM. Maximum total memory supported by the CPU card is 256MB.

Note A minimum of 128MB of memory is recommended for systems running Windows 2000. For additional information about the PowerStation PS Series' memory, see *Physical Specifications* on page 88. If you need to replace memory modules, see the table of *Recommended SDRAM Manufacturers* on page 91.

Memory Map

The following table shows how the PowerStation PS Series allocates conventional and extended memory. Available address references are listed next to each device.

Function	Address Range (decimal)	Address Range (hex)	Size
Extended memory	1024K-524288K	100000-20000000	511MB
Boot block	1008K-1024K	FC000-FFFFFF	16KB
ESCD (plug and play configuration area)	1000K-1008K	FA000-FBFF	8KB
Phoenix system BIOS	896K-1,000K	E0000-F9FF	104KB
Available upper memory (open to ISA and PCI buses)	800K-896K	C8000-DFFFF	96KB
Video memory and BIOS	640K-800K	A0000-C7FFF	160KB
Conventional memory	0K-640K	00000-9FFFF	640KB

Memory Guidelines

If you are using Interact or MachineLogic software, follow the memory guidelines listed in the table below. If you are not using Interact or MachineLogic, you can skip this section.

Memory Type	Runtime	Development
System SDRAM	32MB min. of system memory	32MB of system memory required
Compact Flash (contains both Internal and external CF. Internal is non-removable.)		8MB external Compact Flash can store APM, AMM, GMM, and PTM, plus four additional runtime modules, two drivers, and approximately thirty screens. Extra modules require greater storage capacity (four modules/MB). Up to 1MB is needed to store MachineLogic applications. Log data to the CF only if its size is sufficient or if you are using the CF in conjunction with a hard drive.
Hard drive (optional)	Can store applications and logged data.	Can store any application. 50MB is needed for the MachineShop development suite (toolbar, Interact, and MachineLogic). 10MB is needed for the toolbar alone.
Floppy drive (optional, external)	Can be used to store logged data.	Can store most applications.

CHAPTER 3: INSTALLATION

This chapter provides guidelines for selecting an appropriate location for the PowerStation PS Series. It also gives instructions for mounting the system in an enclosure (or on a panel if you have an RS system) and starting the system.

Chapter Contents

<i>Selecting a Location</i>	36
<i>Mounting the System</i>	38
<i>Starting the System</i>	41

Selecting a Location

The first step in installing your model is to select an appropriate location. This is the most important aspect of installation because the location you select will affect the system's performance, ease-of-use, and life expectancy. This section provides guidelines to follow when selecting a location.

Class I, Division 2 Guidelines

If you purchased a Class I, Division 2-compliant computer, always follow these guidelines in order to maintain a safe operating environment:

- The computer is suitable for use in Class I, Division 2, Groups A, B, C, and D hazardous locations only.



Warning: Explosion Hazard—Do not disconnect equipment or replace or insert cards unless power has been switched off, or the area is known to be non-hazardous.



Warning: Explosion Hazard—Substitution of components may impair suitability for Class 1, Division 2.

- If you are using AC power and mounted a CTC Parker AC adapter on your computer, make sure that the power cord is secured to the computer using the supplied L-bracket.

Environmental Guidelines

The environment is the area where the system will be located.



In general, select a place that limits the system's exposure to adverse conditions, such as dust, oil, moisture, and corrosive vapors.

Faceplate considerations

The faceplate is designed for a Type 4/4X environment. The system's faceplate is resistant to a variety of chemicals. See *Faceplate Chemical Resistance on page 95* for a complete list.

Electrical Guidelines

To minimize unwanted electrical interference, select a location away from machinery that produces intense electrical noise (arc welders, for example).

If you cannot avoid electrical noise, isolate input power to the system, and separate all data communication cables from power lines.

Important In order to comply with UL 508 and 1604 requirements, use copper wire with 60C or 60/75C insulation and a tightening torque of 7.0 lb./in. (0.79 N-m) when connecting field terminal wiring to the system.

To comply with UL 60950 requirements for permanently connected equipment, a readily accessible disconnect device shall be incorporated in the building installation wiring.

The PowerStation PS Series accepts DC input only. To apply AC power, you must use an AC adapter.

Note You can purchase an AC adapter from CTC Parker Automation at 513-831-2340.

Make sure that your power source is completely compatible with the system before starting up. See *Electrical Specifications on page 94* for a list of the system's electrical specifications)

Temperature Guidelines

You can safely operate the system within the temperature range specified in the *Environmental Specifications on page 93*.

Warning If the system is operating inside an enclosure at temperatures above its rated ambient temperature, you must cool the enclosure.

Enclosure Guidelines

Select an enclosure that is large enough to allow free airflow in and around the system.

See *Appendix B: Dimensional Drawings, on page 97*, for the measurements you will need to mount your system. These include the unit's height, width, and depth; and location measurements for drives, ports, and controls).

- Allow a minimum of 2 inches around the unit for airflow.
- If you have a CD-ROM drive, allow at least 3.5" between the enclosure and the left side of the unit so that the CD-ROM drive tray can open.

See *Accessing Ports, Drives, and Other Controls*, on the following page for additional guidelines.

Make sure that the surface where the unit will meet the front panel of the enclosure is flat in order to ensure a NEMA seal.

Accessing Ports, Drives, and Other Controls

As shown in the illustration on page 22, two of the serial ports, the printer port, the USB ports, PS/2 mouse and keyboard ports, Ethernet port, external CF slot, and CD-ROM drive are located on the left side of the unit in all models in the PowerStation PS Series. At the back of the unit are the floppy drive connector, an additional serial port, the video connector, and power connector. Be sure to design your enclosure with these locations in mind.

Important If you have a CD-ROM drive, be sure to allow at least 3.5" between the enclosure and the left side of the unit so that the CD-ROM drive tray can open.

See *Appendix B: Dimensional Drawings, on page 97*, for the location measurements of your system's drives, ports, and controls. Use these dimensions to customize the mounting of your unit.

Mounting the System

Mounting procedures for the PS/PC series and the RS/RC series are different. Follow the procedure for your system, described below.

Mounting the PS/PC

To mount the PS/PC, complete the following steps:

Note Necessary mounting clamps and screws are shipped with your system.

1. Cut a space in which to mount the unit.

The cutout dimensions will depend upon the size of your system's display and are shown in the following table.

Note Mounting dimensions are also available in *Appendix B: Dimensional Drawings on page 97*.

Monitor Size	Cutout Height	Cutout Width
10.4"	9.86" (250.44mm)	12.60"(320.04mm)
12.1"	11.25" (285.75mm)	14.15" (359.41mm)
15.1"	12.40" (314.96mm)	15.90" (403.86mm)

2. Debur the cutout area.
3. Make sure that both sides of the panel mounting surface are clean and flat.
4. Slide the unit into the cutout from the front.
5. Attach the mounting clamps to the back of the unit, as shown in the following illustration.

Note The following image is an illustration of a PXXX-2 model. However the mounting clips are located in the same place on all models.

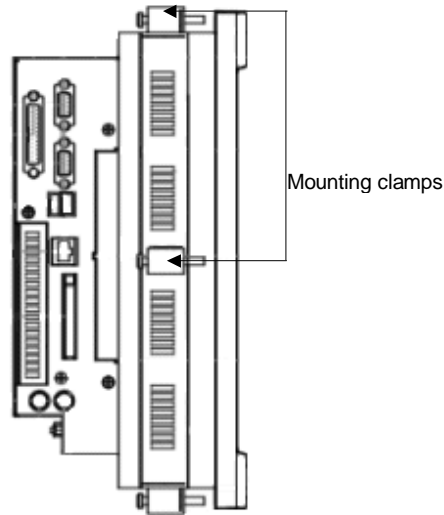

- If you have a system with a 9.5” or 10.4” display, attach 6 mounting clamps, with their screws, to the back of the unit in the spaces provided. You will place 2 clamps at the top and bottom of the unit and 1 on each side, as shown above.
- If you have a system with a 12.1” or 15.1” display, attach 8 mounting clamps, with their screws, to the back of the unit in the spaces provided. You will place 2 clamps at the top and bottom of the unit and 2 on each side.

Note The prongs at the bottom of each clamp should face backward, as in the following illustration, and they should hook into the slots in each space. The end of each screw should point toward the front of the enclosure.

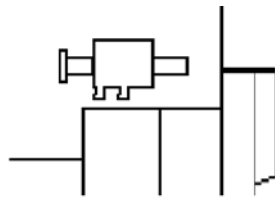

6. Tighten each screw against the front of the enclosure to a torque of 8 lb./in.

Mounting the RS/RC

To mount the system, complete the following steps:

Note Mounting screws are shipped with your system.

1. Drill four mounting holes in the panel where you will mount the system.
Measurements for the mounting holes are shown in *Appendix B: Dimensional Drawings, on page 97*.
2. Make sure that the panel mounting surface is clean and flat.
3. Screw the mounting screws into the holes that you drilled, but do not tighten the screws all the way down.
4. Mount the system by placing the large openings in the mounting slots in the front

cover over the screws in the mounting panel, as shown in the illustration below. Slide the unit downward so that the narrow ends of the mounting slots fit underneath the screw-heads.

The unit should fit snugly on the mounting screws. If the unit fits too loosely, remove it, tighten the mounting screws, and remount the unit.

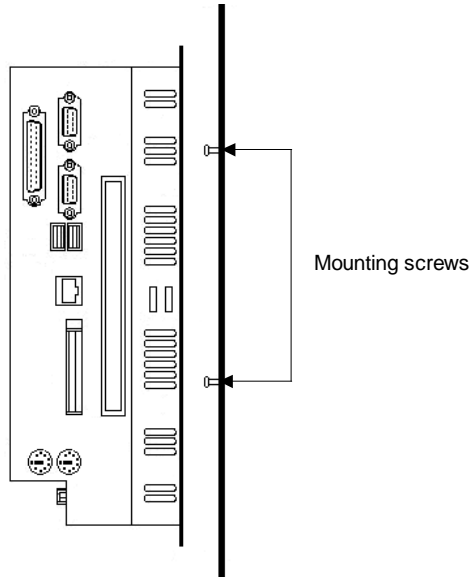

Connecting the RS/RC Unit to a Monitor

Once you have installed the RS/RC unit, you are ready to connect it to a monitor. This section explains how to connect the system either to CTC's PowerStation RS Monitor or to another monitor.

Connecting to a PowerStation RS Monitor

To connect the RS to the PowerStation RS Monitor, connect the following cables:

Note A 15-pin video cable is shipped with the RS Monitor.

1. Connect a 15-pin video cable between the monitor's Analog Video Input port and the video port at the back of the RS computer.

Note A 9-pin touchscreen cable is shipped with the RS Monitor.

2. If you have a touchscreen monitor, follow the steps in *Exploring the BIOS Setup and Configuring Serial Ports* on page 44.
3. Connect a 9-pin touch-screen cable to the 9-pin serial port on the RS Monitor and COM3 at the back of the RS computer.

Connecting to other monitors

- To connect the RS/RC to a non-PowerStation RS Monitor, connect a 15-pin video cable between the video port at the back of the RS/RC computer and the monitor's video port.

Starting the System

Once your system has been mounted, you are ready to start it up. This procedure is described in the following paragraphs.

Before connecting power to the unit, make sure that you have read and understood the *Electrical Specifications on page 94* and *Testing Specifications on page 94*. Also, make sure that you follow the guidelines listed below:

- For permanently connected equipment, a readily accessible disconnect device must be incorporated into the fixed wiring.
- For pluggable equipment, the socket-outlet must be installed near the equipment and should be easily accessible.



Important Proper installation of the system in European Union countries requires the use of a harmonized power cord (the power cord must be identified with the <HAR> symbol). Make sure that the system is connected to the main supply with a harmonized power cord.

1. Connect the power cord to a voltage source.

Voltage input to the system should be within the range specified in *Electrical Specifications on page 94*.

2. Connect the power cord to the system.
3. Turn the system on.

The following are guidelines for starting under Windows 98, or NT; under a multiboot system; or under MS-DOS.

Starting in Windows 98 or 2000

If you are running Windows 98, or 2000 Windows will automatically load at startup.

Starting in Windows NT

To load Windows NT at startup, complete the following steps:

Important You must have a keyboard connected to the system in order to load Windows NT.

1. Start the system, and press **Ctrl+Alt+Delete**.
2. When the Logon Information window prompts you for the Administrator's password, press **Enter**, or click **OK** (the password is blank by default).

3. Click **Close** in the Help window if you do not want Help when you first enter Windows NT.

Starting in Multiboot Systems

When starting in a multiboot system, you will be shown a menu, in which you will have the option of booting into Windows NT or MS-DOS.

- The PowerStation PS models are set to default to Windows NT.
- You may change the default so that when the system starts, it defaults to MS-DOS.

You may wish to do this so that operators do not have to change the default selection every time the system starts.

To set MS-DOS as the default operating system, complete the following steps:

1. On the Windows taskbar, click **Start**; then click **Settings** and **Control Panel**.

The Control Panel window will open.

2. In the Control Panel window, click **System**.

The System Properties dialog box will open.

3. In the System Properties dialog box, click the **Startup/Shutdown** tab.

4. Select **MS-DOS** from the Startup drop-down list.

5. From the **Show List For** spin box, select the number of seconds the menu is displayed upon startup.

6. Click **OK**.

The next time the system starts, the operating system will default to MS-DOS.

Starting in MS-DOS

If you are running a PowerStation PS model under MS-DOS, the MachineShop Shell will automatically be loaded at startup.

You are now ready to begin using your system.

- If you are using Interact or MachineLogic software, refer to the Interact Getting Started Guide or the MachineLogic Getting Started Guide for help in developing your projects.
- Refer to the MachineShop Getting Started Guide for information about how to download projects.

CHAPTER 4: MAINTENANCE AND TROUBLESHOOTING

Occasionally, you may need to perform routine maintenance on some system components. This chapter provides instructions for maintenance, as well as steps for solving problems that may occur in operation.

Chapter Contents

<i>Exploring the BIOS Setup.....</i>	<i>44</i>
<i>Reinstalling Software.....</i>	<i>46</i>
<i>Restoring a Compact Flash Card.....</i>	<i>59</i>
<i>Maintaining the Display on a PS/PC.....</i>	<i>60</i>
<i>Performing Internal Maintenance.....</i>	<i>65</i>
<i>Troubleshooting</i>	<i>75</i>

Exploring the BIOS Setup

If you want to reset any of the BIOS settings, press the **F2** key while the system is starting up to display the BIOS setup window. You will be able to do the following:

- Configure the serial ports
- Reset the disk boot priority
- Adjust the display brightness
- Load the default BIOS settings

Configuring Serial Ports

To configure the serial ports, complete the following steps:

1. Start the system, and while the system is starting up, press the **F2** key on your keyboard.

The PhoenixBIOS Setup Utility screen will appear.

2. Select the **Advanced** tab.
3. Scroll down to **PCI Configuration: I/O Device Configuration**.
4. Press **Enter**.

A list of Serial Ports is displayed. See the table below.

A	3F8	4
B	2F8	3
C	2E8	9
Touchscreen	3E8	11

Note The default setting for the touchscreen is enabled. The RS/RC touchscreen setting is manually set to disabled at the factory before it is shipped.

5. To configure all serial ports to the factory defaults, select F9.

Resetting Disk Boot Priority

To reset the disk boot priority, complete the following steps:

1. Start the system, and while the system is starting up, press the **F2** key on your keyboard.

The PhoenixBIOS Setup Utility screen will appear.

2. Select the Main tab if it is not displayed.
3. Scroll down to boot options.

Note The plus sign displayed next to the device represents a submenu. Repeat step four to select the priority of the devices on the submenu.

4. Press the + or – sign on the keyboard to select the priority of the device.

Adjusting Brightness and Contrast

On the TFT displays, you can adjust the brightness, and on the monochrome STN displays, you can control the contrast.

Note Install the Flat Panel Control driver from the PowerStation PC Drivers and Utilities CD (DCD-1000) to adjust the brightness and the contrast without going into the BIOS.

To adjust the brightness on a TFT display or the contrast on the monochrome STN display, complete the following steps:

1. Start the system, and while the system is starting up, press the **F2** key on your keyboard.

The PhoenixBIOS Setup Utility screen will appear.

2. Select the **Advanced** menu.
3. From the Advanced menu, select **LCD Configuration**.

The LCD Configuration screen will appear, showing four options for adjusting the display **Brightness**:

- Maximum (maximum brightness or contrast)
 - Increase (increases brightness or contrast incrementally)
 - Decrease (decreases brightness or contrast incrementally)
 - Minimum (minimum brightness or contrast)
4. If you wish to adjust brightness, select one of the options, and then press **Enter**.
You should see the display brightness or contrast change on your screen.

Loading Default BIOS Settings

To reload the default BIOS settings, complete the following steps:

1. Start the system, and while the system is starting up, press the **F2** key on your keyboard.
2. The PhoenixBIOS Setup Utility screen will appear.
3. In the **Exit** menu, select the **Load Setup Defaults** option.
4. In the Advanced menu, change the **Reset Configuration Data** to **Yes**.
When the system restarts, this setting will automatically switch back to **No**.
5. Save these settings, and exit the setup program.
6. Restart the system.

When the system restarts, the default BIOS settings will be re-established.

Reinstalling Software

The PS/RS models come pre-loaded with the operating system and all of the other software that you purchased. This software may be installed on your system's hard drive if you have purchased one, or on the system's internal or external Compact Flash cards. (See *Drive Functions* on page 21 for information about how a hard drive and CF cards work in your system.)

Backup copies of your software are provided on the CDs and floppy disks shipped with your system. If any of the software on your system becomes lost or corrupted, you can reinstall it from these distribution disks.

This discussion of reinstalling software is organized into three parts:

- *Reinstalling Software on Systems Running Windows*
- *Reinstalling PowerStation Software on Systems Running MS-DOS* (for runtime systems only)
- *Restoring a Compact Flash Card* (for runtime systems only)

Reinstalling Software on Systems Running Windows

This section explains how to reinstall necessary software on systems running Windows 98, 2000, or NT 4.0. If you do not have a system that runs Windows, you may skip this section.

Note To reinstall the software described in this section, you must have a CD-ROM drive installed on your system.

To reinstall software on systems running Windows, you will need the following CDs/disks:

- Windows 98, NT 4.0, or 2000 distribution CD/disks

In this section, you will learn how to complete the following procedures:

- *Repairing Windows*
- *Reinstalling the touchscreen driver*
- *Reinstalling the network driver*
- *Reinstalling PowerSmart*
- *Reinstalling MachineShop* (PowerStations only)

Note If you need additional help reinstalling any of the software described in this section, consult the readme files included on the Industrial PC Drivers and Utilities CD, or call our Technical Support department at 513-248-1714.

Repairing Windows from the Emergency Recovery Disk

If the operating system becomes damaged, you have the option of repairing the system in one of two ways: you can perform a clean install from the CD and reinstall all of your software, or you can repair the system using the Emergency Recovery Disk.

Repairing the operating system from the Emergency Recovery Disk allows you to reinstall basic operating system components that are damaged while leaving the registry intact. This means you will not have to reinstall the software or adjust the settings on your unit. The Emergency Recovery Disk also allows you to customize the installation and specify which components you need reinstalled such as a CD ROM driver.

To repair windows, you will need the following:

To Install . . .	You will need . . .
Windows 98	<ul style="list-style-type: none"> Windows 98 distribution CD Windows 98 Boot Disk (included with the distribution CD)
Windows 2000	<ul style="list-style-type: none"> Windows 2000 distribution CD Windows 2000 Emergency Recovery Disk
Windows NT 4	Win NT 4.0 Emergency Recovery Disk (KA-73057)

To repair Windows 98 using the Emergency Recovery disk, complete the following steps:

1. Insert the Windows 98 distribution CD into the system's CD-ROM drive.
2. Start the system.

A screen will appear offering three start-up alternatives.

3. Type **1** for **Start Windows 98 Setup from CD-ROM**.
4. Press **Enter** to execute this command.

Windows will load several drivers. Then the Welcome to Windows 98 Setup screen will appear.

5. Press **Enter** to install Windows 98.

When installation is complete, remove all disks, and restart the system.

Note You must restart the system for your installation to take effect.

After reinstalling the operating system, you will have to reinstall the video, touchscreen, network, and PowerSmart drivers. For instructions, see the following:

- *Reinstalling the video driver on page 48*
- *Reinstalling the touchscreen driver on page 50*
- *Reinstalling the network driver on page 54*
- *Reinstalling PowerSmart on page 55*

To repair Windows 2000 using the Emergency Recovery Disk, complete the following steps:

1. Insert the Windows 2000 CD to reboot.
A prompt will display asking you to press any key to boot from the CD.
2. Press any key to continue.
3. Follow the instructions to repair the operating system.

Note You must restart the system for your installation to take effect.

4. When installation is complete, remove all disks and restart the system.

Note If the steps above do not fix windows, then re-start the computer and re-install windows instead of repairing it.

After reinstalling the operating system, you will have to reinstall the PowerSmart drivers. For instructions, see *Reinstalling PowerSmart on page 55*.

To repair Windows NT 4.0 using the Emergency Recovery Disk:

If you have an external floppy drive,

1. Insert the Win NT 4.0 Emergency Recovery Disk into the system's floppy disk drive.
2. Start the system, and follow the prompts to reinstall Windows NT and the CD-ROM driver.
3. When installation is complete, remove all disks, and restart the system.

If you are using a CD ROM Drive,

1. Insert the windows NT 4.0 CD into the CD ROM drive.
2. Reboot to the CD.
3. Follow the instructions to repair the hard drive.
4. If you reboot to the hard drive, and the problem still isn't fixed, then reboot to the CD and reinstall windows.

Note You must restart the system for your installation to take effect.

After reinstalling the operating system, you will have to reinstall the video, touchscreen, and network drivers. For instructions, see the following:

- *Reinstalling the video driver on page 48*
- *Reinstalling the touchscreen driver on page 50*
- *Reinstalling the network driver on page 54*

Reinstalling the video driver

Note Under Windows 2000 the video driver is incorporated into the operating system. So if you've installed the operating system, you've already installed the video driver.

Use the following instructions to reinstall the Chips 69000 video driver under Windows 98, or NT 4.0.

To reinstall the video driver under Windows 98, complete the following steps:

1. Start the system, and insert the Drivers and Utilities CD into the system's CD-ROM drive.
2. On the Windows taskbar, click **Start** and then **Run**.
3. Next to the word **Open**, type **D:\Drivers\Video\98\w98600.exe**, and then click **OK**.

Note In this example, D represents the letter of your CD-ROM drive. If your system has assigned a different letter to the CD-ROM drive, type the appropriate letter.

4. Follow the installation wizard to install the video driver.
5. When the installation is complete, restart the system.

Note You must restart the system for your installation to take effect.

To reinstall the video driver under Windows NT 4.0, complete the following steps:

1. Start the system.
2. On the Windows taskbar, click **Start**; then click **Settings** and **Control Panel**.
The Control Panel will appear.
3. Click **Display**.
The Display Properties dialog box will appear.
4. Click the **Settings** tab.
The Settings dialog box will appear.
5. Click **Display Type**.
The Change Display Type dialog box will appear.
6. Click **Change in Adapter Type**.
The Select Device dialog box will appear.
7. Insert the Drivers and Utilities CD into the system's CD-ROM drive.
8. Click **Have Disk**.
The Install from Disk dialog box will appear.
9. Under "Copy manufacturer's files from," type **D:\Drivers\Video\WINNT 40**, and then click **OK**.

Note In this example, D represents the letter of your CD-ROM drive. If your system has assigned a different letter to the CD-ROM drive, type the appropriate letter.

10. Select **Chips Video Accelerator** from the Display list, and then click **OK**.

A warning about third-party drivers will appear.

11. Click **Yes** to complete the installation.
12. When installation is complete, restart the system.

Note You must restart the system for your installation to take effect.

Reinstalling the touchscreen driver

The touchscreen driver in the PowerStation PS Series is the Touchbase Universal Pointing Device Driver (UPDD). Use the following instructions to install the driver under Windows 98, 2000, or NT 4.0. If you have an RS system, you may skip this section.

Reinstalling the touchscreen driver under MS-DOS

This section describes how to install the touchscreen driver and utilities in systems running MS-DOS. It covers the following topics:

- Installing the touchscreen driver and utilities
- Operating a mouse and touchscreen concurrently

Important To install the touchscreen software in your computer, you must have MS-DOS running, and you must have a floppy disk drive connected.

Reinstalling the driver

To reinstall the touchscreen driver under MS-DOS, complete the following steps:

1. Insert the PowerStation Start Diskette (SA-83109-105) into drive A.
2. Select the A drive.
3. At the DOS prompt, type install A: C:
4. Press **Enter** to execute the command.

When the command is finished executing the DOS prompt is displayed.

5. Remove the installation diskette from the floppy drive.

Note You must restart the computer for your installation to take effect.

6. Restart your computer.

The files in the table on the following page will be placed in the \TOUCH directory on your hard drive.

Directory	File
\TOUCH	TBDriver
	TBDDemo
	TBCal
	TBDiag
	TBMouse

Note When the touchscreen software is installed, the configuration parameters will be set according to your desired configuration. You should not need to change them.

7. To change the address or IRQ's from the touch directory, type the following line to get the command options.

Note Include a space between tbdriver and the backslash.

C:\TOUCH>tbdriver /?

Reinstalling the touchscreen driver under Windows 98, or NT

To reinstall the touchscreen driver under Windows 98, or NT, you will install the driver, and then you will verify the settings.

Reinstalling the driver

To install the driver under Windows 98, or NT, complete the following steps:

1. Remove the backshell of the PowerStation to access the IRQ jumper settings.
2. Locate the Jumper Settings. Refer to *Changing Jumper Settings on page 71* of this User Guide for the location.
3. Write down the I/O port address and the IRQ settings and set aside. Match the default settings listed below.

The default setting for the I/O Port is 3E8 and the IRQ is 11.

4. Install the backshell.
5. Insert the Drivers and Utilities CD into your system's CD-ROM drive.
6. On the Windows taskbar, click **Start** and then **Run**.
7. Next to the word "Open," type the following path.

Note In the following example, [Drive] represents the letter of your CD-ROM drive. If your system has assigned a different letter to the CD-ROM drive, type the appropriate letter.

[Drive]:\Drivers\Touch\UPDD\Setup.exe.

8. Click **OK**.
9. Follow the installation wizard to install the driver.
10. After installation is complete, restart the computer.

Note You must restart the computer for your installation to take effect.

Verifying the settings

To verify that the system recognizes the correct IRQ and I/O Port Address settings, complete the following:

1. Select **Start-Programs-UPDD-Settings**.

The Pointer Device Properties window will appear.

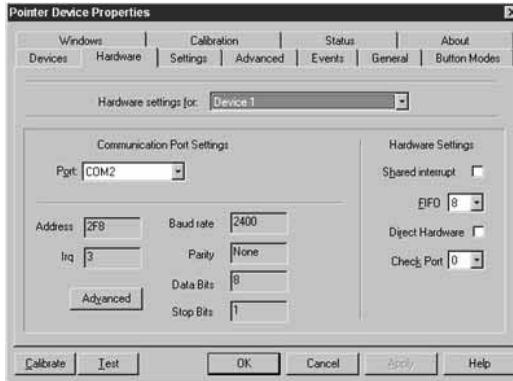

2. Select the **Hardware** tab.
3. Compare the Address and IRQ settings with the jumper settings that you verified in step 3 of the installation procedure in the previous section.
4. Complete one of the following:

Settings	Action
If the settings match	Continue with step 5.
If the settings do not match	<ol style="list-style-type: none"> 1. Press the Advanced button. 2. Change the Address and IRQ settings to match the settings in step 3 of the previous section. 3. Press Okay. 4. Press Apply.

5. Calibrate the touchscreen if necessary.

For instructions, see *Recalibrating the Touchscreen* on page 62.

Reinstalling the touchscreen driver under Windows 2000

To install the touchscreen driver under Windows 2000, you will identify the driver COM port or install a new COM port (first time installation), install the driver, and then configure the driver settings.

Identifying the driver COM port

How you identify the driver COM port will depend upon whether you are replacing an existing installation of the driver (e.g., a corrupted driver) or installing the driver on a computer for the first time (e.g., under a new operating system).

- If you are reinstalling the driver to replace an existing installation, you must determine the present driver COM port, using the Windows Device Manager.
- If you are installing the driver for the first time, you must install a new driver COM port, using the Add New Hardware Wizard.

To identify the present touchscreen driver COM port, complete the following steps:

1. On the Windows taskbar, select **Start** and then **Settings**.

2. On the Settings submenu, select **Control Panel**.
The Control Panel will appear.
3. In Control Panel, open the **System** directory.
The System Properties dialog box will appear.
4. In the System Properties dialog box, select the **Hardware** tab.
5. On the Hardware tab, select the **Device Manager** button.
The Device Manager menu will appear.
6. On the Device Manager menu, open the **Ports** directory.
7. Double-click on a port.

Note The most likely choice is the last port in the list.

The port's Properties sheet will appear.

8. Select the **Resources** tab, and look in the **Resource settings** group box to determine if the port uses **3E8** and **IRQ 11**.
This will be the touchscreen driver COM port.
9. Check each port until you find the touchscreen driver COM port; then make a note of this port to use when you install the touchscreen driver.

Reinstalling the touchscreen driver

To install the touchscreen driver, complete the following steps:

Important To install the touchscreen driver, you must know the driver COM port number. If you are not sure what this number is, complete steps 1-9 under Identifying the Com port.

1. Insert the UPDD Drivers and Utilities CD into your computer's CD-ROM drive.
2. Run **D:\drivers\touch\UPDD\RS9\Setup.exe**
3. Choose the COM port that matches the hardware settings from the table below.

Address	COM Port
3F8	1
2F8	2
3E8	3
2E8	4

4. Press **Finish** after the installation is complete.
5. Restart the computer.
6. **Calibrate** the touchscreen if necessary.

For instructions, see *Recalibrating the Touchscreen* on page 62.

Note Once the touchscreen driver is installed, you can create a UPDD “clone” file that you can copy to your Touch directory and use if you need to reinstall the driver under Windows 2000. The clone file greatly simplifies the installation procedure. See the UPDD online Help for instructions on how to create and use this clone file.

Reinstalling the network driver

Use the following instructions to install the Pro/100B Ethernet driver under Windows 98, or NT 4.0.

Note Under Windows 2000, the network driver loads automatically when Windows 2000 is installed.

To reinstall the network driver under Windows 98, complete the following steps:

1. Start the system.
2. On the Windows taskbar, click **Start ► Settings ► Control Panel**.
The Control Panel will appear.
3. Click **System**.
The System Properties dialog box will appear.
4. Click the **Device Manager** tab.
5. Click the + sign next to **Network adapters**.
A list of installed network drivers will appear.
6. Select the **Intel 825X-Based PCI Ethernet Adapter (10/100)**.

Note This driver should have an exclamation point (!) next to it.

7. Click **Remove**, and follow the prompts on screen to uninstall the driver.
8. Restart the system.
The New Hardware Found dialog box will appear. It will identify the network adapter as a **PCI Ethernet Controller**.
9. Insert the Drivers and Utilities CD into the system’s CD-ROM drive.
10. In the **Update Device Driver Wizard**, click **Next**.
The wizard will list the driver it has found as **Intel (R) PRO/100+ PCI Adapter**.
11. Click **Finish**.

Note You must restart the system for your installation to take effect.

12. When installation is complete, restart the system.

To reinstall the network driver under Windows NT 4.0, complete the following steps:

1. Start the system.
2. On the Windows taskbar, click **Start ► Settings ► Control Panel**.
The Control Panel will appear.
3. Click **Network**.
The Network dialog box will appear.
4. Click the **Adapter** tab.
5. On the Adapter tab, click **Add**.
The Select Network Adapters dialog box will appear with a list of installed network drivers.
6. Do not select a driver from this list. Instead, insert the Drivers and Utilities CD into the system's CD-ROM drive.



Important You must load the Ethernet driver provided by CTC Parker. Using any of the drivers provided by Windows will cause a General Protection Fault; all programs will fail to respond.

7. Click **Have Disk**.
The Install from Disk dialog box will appear.
8. Under "Copy manufacturer's files from," type **D:\Drivers\Pro100 Ethernet**, and then click **OK**.

Note In this example, D represents the letter of your CD-ROM drive. If your system has assigned a different letter to the CD-ROM drive, type the appropriate letter.

9. Follow the prompts to complete the installation.

Note You must restart the system for your installation to take effect.

10. When installation is complete, restart the system.

Reinstalling PowerSmart

Use the following instructions to reinstall the PowerSmart system monitor utility under Windows 98, Windows 2000, Windows XP or NT 4.0.

To reinstall PowerSmart, complete the following steps:

1. Start the system, and insert the Industrial PC Drivers and Utilities CD (DCD-1000) into the system's CD-ROM drive.
2. On the Windows taskbar, click **Start** and then **Run**.

Note In the following example, D represents the letter of your CD-ROM drive. If your system has assigned a different letter to the CD-ROM drive, type the appropriate letter.

3. Next to the word “Open,” type **D:\PowerSmart\WIN\Setup.exe**, and then click **OK**.
4. Follow the installation wizard.
5. When installation is complete, restart the system.

Note You must restart the system for your installation to take effect.

Reinstalling MachineShop

Use the following instructions to reinstall the MachineShop development suite or any of its components on one of the PowerStation PS models. If you do not have a PowerStation, you can skip this section.

1. Insert the MachineShop Installation CD (version KA-83103 or later) into the PowerStation’s CD-ROM drive.

If automatic installation is enabled on your system, installation will begin, and the Setup Welcome dialog box will appear. Go to step 4.

If automatic installation is disabled, complete steps 2-3.

2. On the Windows taskbar, click **Start**, and then click **Run**.

The Run dialog box will appear.

Note In the following example, **D** represents **Drive**.

3. In the Run dialog box, next to the word “Open,” type **D:\Setup.exe**, and click **OK**. If necessary, substitute your CD-ROM drive letter for **D**.

The Setup Welcome dialog box will appear.

If you have previously installed MachineShop, a special Setup Welcome dialog box will appear allowing you to modify, repair, or remove the installation. If you select **Modify**, and click **Next**, the Select Operation dialog box will appear.

4. Click MachineShop Suite, and follow the installation wizard to install MachineShop.

Note You may choose to install Adobe Acrobat 4.0 as part of your suite installation. If, after Acrobat 4.0 installs, you are prompted to restart your computer, select **No**, and then click **Finish** to allow your system to complete the MachineShop Suite installation.

Reinstalling PowerStation Software on Systems Running MS-DOS

This section explains how to reinstall the MachineShop Shell, and essential drivers and PowerStation utilities on your system. The procedures described below must be completed under MS-DOS. If you are running Windows 98 or NT on your system, restart the system in MS-DOS mode. If you need additional help reinstalling drivers and utilities, call our Technical Support department at 513-248-1714.

Note To reinstall the software described in this section, you must have a floppy disk drive installed on your PowerStation.

Reinstalling the MachineShop Shell

To reinstall the MachineShop Shell, complete the following steps:

1. Insert the MachineShop Shell Installation Disk into the system's floppy disk drive.

Note The MachineShop Shell Installation Disk is part of the Runtime Workstation Disk Set, which you can create from the MachineShop Installation CD (KA-83103). See the *MachineShop Installation Booklet* for instructions on how to create this disk.

2. If necessary, change to the root directory of drive A by typing **A: .**
3. Press **Enter** to execute this command.
4. At the DOS prompt, type **Install A: C:**

Note In this example, C represents the drive letter of the device on which you want to install the MachineShop Shell—either a hard drive or CF card. If you are using both a hard drive and a CF card in your system, type the appropriate drive letter.

5. Press **Enter** to execute this command.

You will be asked if you want to continue with the installation.

6. Type **Y** for Yes in order to continue.

The system will copy the MachineShop Shell files onto the system's hard drive or CF card. It will copy Shell files into the CTC directory.

Note The touchscreen drivers are copied into the Touch\Dox directory, and network drivers are copied into the Net directory from the Start disk that came with your unit.

7. Restart the system.

Note You must restart the system for your installation to take effect.

The system will display the MachineShop Shell.

Reinstalling drivers and PowerStation utilities

The PowerStation drivers and utilities are stored in a zipped folder on the PowerStation Start Disk (SA-83109-105).

To reinstall all necessary drivers and utilities in the PowerStation PS Series, complete the following steps:

1. Insert the PowerStation Start Disk into the system's floppy disk drive.
2. If necessary, change to the root directory of drive A by typing **A:**
3. Press **Enter** to execute this command.
4. At the DOS prompt, type **Install A: C:**

Note In this example, C represents the drive letter of the device on which you want to install the PowerStation Utilities—either a hard drive or CF card. If you are using both a hard drive and a CF card in your system, type the appropriate drive letter.

5. Press **Enter** to execute this command.

You will be asked if this installation is for a Model P1.

6. Type **N** for No.

7. You will be asked if this installation is for a Model P9.

Type **N** for No.

The system will copy the necessary PowerStation files from the Start Disk and unzip them.

At the end of the installation, you will be asked if you would like the factory-default **Autoexec.bat** and **Config.sys** files to be copied to the root directory of drive C.

- If you answer **Yes**, the existing Autoexec.bat and Config.sys files will be renamed as Autoexec.old and Config.old.
- If you answer **No**, the factory-default files will be copied as Autoexec.ctc and Config.ctc in the CTC directory of drive C.

8. We recommend that you type **Y** for Yes.

9. After the Autoexec.bat and Config.sys files have been copied onto your system, press any key to continue.

The PowerStation utilities installation is complete.

You will be asked if you want to recalibrate the touchscreen.

10. If you have a system with touchscreen, type **Y** for Yes, and recalibrate the touchscreen (see *Recalibrating the Touchscreen on page 62* for instructions). If you do not have a touchscreen, type **N** for No.

At this point, you will be prompted to install the MachineShop Shell. If you have to do this, see *Reinstalling the MachineShop Shell on page 57* for instructions.

Note You must restart the system for your installation to take effect.

Restoring a Compact Flash Card

If you use a Compact Flash (CF) card as the startup drive in a PowerStation, you may need to create a bootable CF card for the system from a blank or used card. This procedure will fix a DOS Shell Compact Flash and allow you to do the following:

- Replace deleted or corrupted files on a CF card
- Prepare a new card for use

Note If you do not have a PowerStation that runs on a CF card, you can skip this section.

You can easily reformat a Compact Flash card by using CTC's FlashBack utility, which restores the MS-DOS operating system and PowerStation operating files to a CF card in one, simple operation. To do this, you will open FlashBack on the MachineShop Installation CD (KA-83102) shipped with your system and use the instructions in the FlashBack online help to reformat the CF card.

Important The following steps should be completed on a white box with a San disk or PCMCIA to Compact Flash Adaptor, described below, you must have a CD-ROM drive installed on your PowerStation.

To reformat a CF card for a model in the PowerStation PS Series, complete the following steps:

1. Insert the MachineShop Installation CD (version KA-83102 or later) into the CD-ROM drive of a white box.
2. Use Windows Explorer to locate the file **FlashUtil.exe** on the CD-ROM drive.

It will be in the **Utilities ► Flashback** directory.

3. Double-click **FlashUtil.exe**.

The FlashBack Utility dialog box will appear.

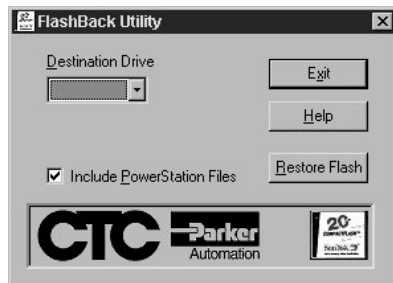

4. Click the **Help** button to find complete, online instructions for using the FlashBack utility.

Maintaining the Display on a PS/PC

Note If you have an RS/RC system (without display), you may skip this section.

This section contains instructions for the following:

- Cleaning the display screen
- Reconfiguring the touchscreen driver
- Recalibrating the touchscreen

Note For instructions on how to adjust the display brightness, *Adjusting Brightness on page 45*.

Cleaning the Display Screen

- If you wish to clean the display screen, do so using warm, soapy water and a cloth.
- You also may use any non-abrasive cleaner.
- Do not use any harsh material or powder, such as steel wool or abrasive cleansers.
- See *Faceplate Chemical Resistance on page 95* for a list of substances the screen can resist with no visible effect.



Important PowerStation users: Do not clean the unit while Interact is in Run mode. Clean the unit only when power is off to keep from inadvertently activating an Interact device (button, slide, etc.).

If you have a touchscreen monitor, the touchscreen surface is sensitive to scraping, sharp blows, or punctures. Therefore, keep screwdrivers or other sharp objects away from the surface.

Reconfiguring the Touchscreen Driver

Your system will be shipped with one of the following touchscreen drivers installed and configured. The Touchscreen driver installed will depend upon your computer's operating system:

Operating System	Driver
DOS	TouchBase Driver
Windows	Universal Pointing Device Driver (UPDD)

You may have to reconfigure the touchscreen driver if it becomes corrupted, if you reinstall it, or if you wish to change the touchscreen jumper settings in your computer.

This section explains how to reconfigure the touchscreen driver under Windows 98, 2000, or NT 4.0 and under MS-DOS (PowerStations only).

Reconfiguring under Windows

To configure the touchscreen driver under Windows 98, 2000, or NT 4.0, complete the following steps:

1. Select **Start-Programs-UPDD-Settings**.

The Pointer Device Properties window will appear.

2. Select the **Hardware** tab.

The Hardware dialog box will appear as shown below.

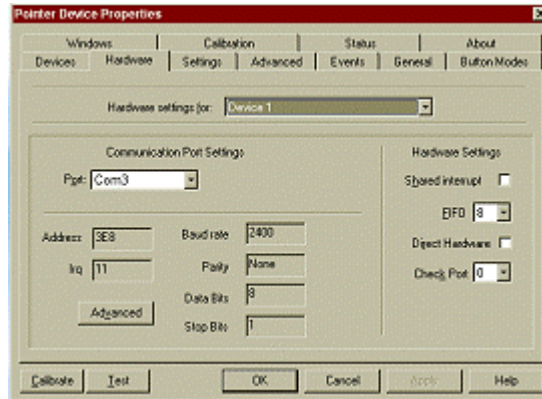

The following table displays the default settings for the touchscreen.

Port	COM3
Interrupt IRQ	11
Address	3E8

3. Click the drop-down arrows to change the Communication Port and Hardware settings.
4. Click **Advanced** to change the Address and IRQ settings.
5. Click **OK** when you are finished.
6. Click **OK**.
7. If the changes have no effect, restart the system.

Reconfiguring under MS-DOS (PS and RS models only)

To configure the touchscreen driver on a system with MS-DOS, complete the following steps:

1. Start the system.

The DOS C:\ prompt will appear.

Note If the system boots to MachineShop Shell, exit the Shell.

2. At the C:\ prompt, type **Edit Autoexec.bat**.

The text of the Autoexec.bat file will appear.

3. Select one of the following:

- If you wish to re-establish the factory default settings for your touchscreen address and IRQ, make sure that the following lines near the beginning of the Autoexec.bat file read as follows:
 - SET TOUCH_ADDR=3E8
 - SET TOUCH_IRQ=11
- If you intend to change the touchscreen jumper settings, change the preceding lines to reflect the new touchscreen address and IRQ.

4. Restart the system.

Note You must restart the system for your changes to take effect.

Recalibrating the Touchscreen

Your system's touchscreen will be calibrated at the factory. However, you may need to calibrate the touchscreen when you use the system for the first time or whenever the cursor location and the place on the screen where the user touches do not match.

- If you are running Windows, you can calibrate the touchscreen under Windows 98, 2000, or NT 4.0.
- If you are running a PowerStation under MS-DOS, you can calibrate the touchscreen under DOS from the MachineShop Shell.

Recalibrating under Windows

To recalibrate the touchscreen under Windows 98, 2000, or NT 4.0, complete the following steps:

1. Select **Start-Programs-UPDD-Settings**.

The Pointer Device Properties window will appear.

2. Select the **Calibration** tab.

The Calibration dialog box will appear as shown below.

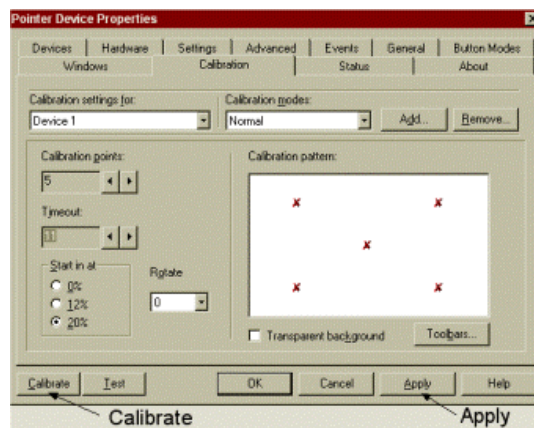

3. Use the arrows to select the settings.

4. Press **Apply**.

5. Press **Calibrate**.
6. Place your finger on the arrow in the upper left corner of the screen.
The arrow will automatically advance to the next corner when you touch it.
7. Touch the **Arrow** in each of the three subsequent corners.
A confirmation test screen will display that allows you to test the calibration with your finger.
8. Test the calibration.
9. Press **Esc** to return to the calibration dialogue box.
10. Complete one of the following:
 - If the touchscreen appears calibrated, press **OK** to close the UPDD.
 - If the touchscreen does not appear calibrated, open the Advanced folder on the UPDD dialog box.
11. Check or uncheck the x-y swap setting.
12. Press **Apply** to accept the change.
13. Press **OK** to close the UPDD.

Important If the touchscreen still does not appear calibrated, and the cursor moves vertically when your finger moves horizontally on the screen or vice versa, the touchscreen cable may not be connected to the motherboard properly. Call a CTC customer service representative.

Recalibrating under MS-DOS (PS and PC models only)

To recalibrate the touchscreen under MS-DOS (from the MachineShop Shell), complete the following steps:

Note This procedure requires a keyboard.

1. On the MachineShop Shell main menu, press the **Settings** button.

The Settings submenu will appear.

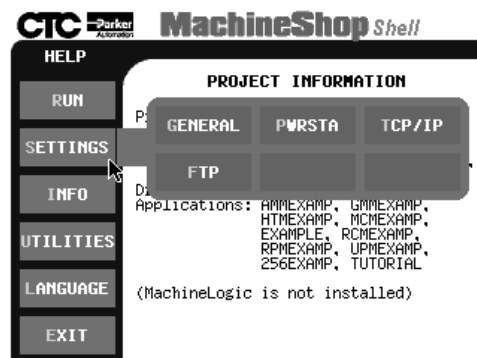

2. Press the **PWRSTA** button.

The PowerStation Settings submenu will appear.

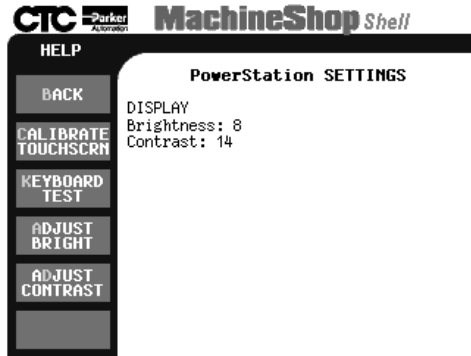

3. On the PowerStation Settings submenu, press the **Calibrate Touchscrn** button.

You will be prompted that a keyboard is needed to calibrate the touchscreen. Then you will be asked if you want to continue.

4. If necessary, connect a keyboard to the system.
5. When you have connected a keyboard, press the **Yes** button to continue the calibration.

The Touchscreen Calibration screen will appear.

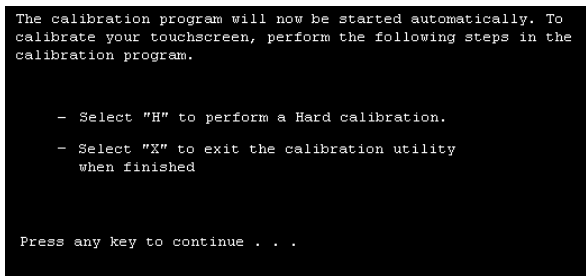

6. Press any key on the keyboard when you are ready to begin calibration.

The Touchscreen Driver Configuration screen will appear.

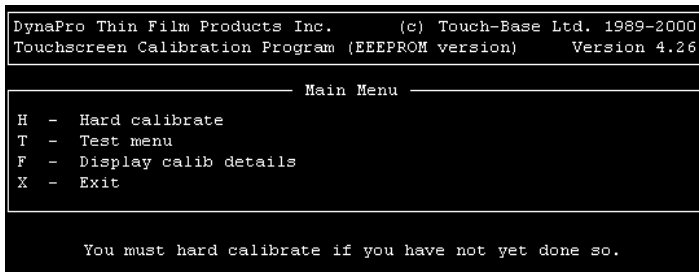

7. Type **H** for Hard Calibration.
8. Press **Esc** or **X** to exit the calibration utility.



Important After calibrating the touchscreen, enter Interact in Program Mode. Verify that the cursor appears on the screen where you touch. If it does not, recalibrate the touchscreen. The calibration must be accurate to avoid activating a button unintentionally during Run mode.

Performing Internal Maintenance

This section includes important information about performing internal maintenance on the PowerStation PS, including:

- Replacing field-replaceable components
- Observing electrostatic discharge (ESD) precautions
- Opening and closing the system
- Adding expansion cards
- Changing jumper settings

Replacing Components

The following components are field-replaceable.

- Backlight bulbs
- Battery
- CD-ROM drive
- Floppy disk drive
- Fuse
- Hard disk drive
- SDRAM modules
- Touchscreen

We recommend that you order replacement components and installation kits from CTC Parker at 513-831-2340.

- Replacement components purchased from CTC are designed and tested to work effectively in your system.
- Complete installation instructions are included with each item.

Note If you wish to purchase replacement components from another source, call our Technical Support department at 513-248-1714 for a list of recommended manufacturers. A table of *Recommended SDRAM Manufacturers* appears on page 91.



Observing ESD Precautions

Modern integrated electronic devices, especially circuit cards and memory chips, are extremely sensitive to electrostatic discharges (ESD) and fields. Before you open the system, be sure to follow these simple precautions to protect you and the unit from harm resulting from ESD:

- Always disconnect the power from the unit before you remove the backshell. Do not touch any cards while the unit is on.
- Disconnect power before making any hardware configuration changes. The sudden rush of power as you connect a jumper or install an expansion card may damage electronic components.
- Only handle internal components in an ESD-safe location, using appropriate grounding methods.
- Wear a grounding wrist strap for continuous protection.
- Always ground yourself before you touch a card.
- Do not touch the chips on a card.
- Keep any card in its anti-static packaging when it is not installed in the system; place it on a static dissipative mat when you are working on it.

Opening and Closing the System

In order to perform internal maintenance on the PS/PC or the RS/RC, you will have to open and close the backshell. Instructions for both procedures follow.



Opening the system

Warning For safety reasons, the system should be opened only by qualified service personnel.

To access the board, complete the following steps:

1. Turn off the system.
2. Disconnect the system from the power source.
3. Disconnect all cables attached to the system.
4. Remove the four screws from the backcover of the unit (see the figure below) and set aside.

Note The unit illustrated below is a PS15-3. However, the screws are located in the same place for all units within the PowerStation PS series regardless of the model number.

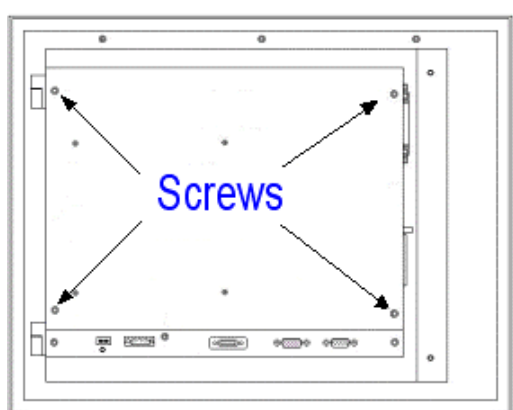

- If you own a unit with ISA or PCI cards, you will need to remove the bracket that holds the cards in place.

The backcover is removed and the board is accessible.

To access the hard drive, complete the following steps:

- Complete steps one through five under *To access the board on page 66*, then continue with step 2.
- Detach the flat panel cable if the unit is attached to a display.
- Detach the touchscreen cable, if the unit is attached to a display.
- Remove the eight screws (two per side) that attach the backshell to the touchscreen.

Note The unit illustrated below is an RS00-3. However, the screws are located in the same place for all units within the PowerStation PS series regardless of the model number.

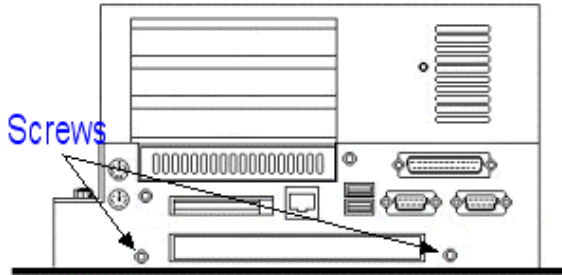

- Lift the backshell to one side and slide the cables through the slot.
- Set the backshell aside.

The backshell is removed.

To remove the touchscreen, complete the following steps:

- Complete steps one through six under *To access the board on page 66*. Then continue with step 2 below:
- Detach the flat panel cable.
- Detach the touchscreen cable.
- Complete one of the following:

Type of Unit	Action
PS10/PC10	Remove the 8 screws on the sides of the unit that attach the backshell to the touchscreen.
PS12 or PS15/PC12 or 15	<ol style="list-style-type: none"> Remove the two screws on the adaptor plate that connect the backshell to the touchscreen. Detach the adapter plate and backshell from the hinge on the touchscreen by sliding it toward or away from you depending on the position of the unit.

- Tilt the backshell to one side and slide the touchscreen cables through the slot on the backshell.
- Set aside the adapter plate with the backshell still attached to it.

Closing the system

To install the touchscreen, complete the following steps:

1. Place the backshell on the touchscreen.
2. Tilt the backshell to one side and slide the touchscreen cables through the slot on the backshell.
3. Complete one of the following:

Type of Unit	Action
PS10/PC10	<ol style="list-style-type: none"> 1. Position the backshell onto the touchscreen ensuring the 8 screw tabs on the touchscreen are positioned inside the backshell. 2. Tighten with the 8 screws that were previously removed.
PS12 or PS15/PC12 or PC15	<ol style="list-style-type: none"> 1. Connect the hinges on the adapter plate to the hinges on the touchscreen sliding them into place (the backshell should already be attached to the adaptor plate). 2. Secure the adaptor and backshell to the touchscreen using the two screws previously removed.

4. Attach the flat panel cable to the board.
5. Attach the touchscreen cable to the board.
6. Complete the steps for installing the backcover.

To install the backshell complete the following steps:

1. If you are using a display, tilt the backshell to one side of the unit and slide the flat panel and touchscreen cable through the slot.
2. Position the backshell onto the touchscreen making sure the 8 screw tabs on the touchscreen are positioned inside the backshell.
3. Attach the backshell using the eight screws previously removed from the unit.
4. If using a display, attach the flat panel cable and the touchscreen cable to the board.
5. Continue with the steps below for installing the backcover.

To install the backcover to the unit, complete the following steps:

1. If you own a unit that uses ISA or PCI cards, you will need to install the bracket that holds the cards in place.
2. Place the backcover onto the unit.
3. Secure the backcover using the four screws removed when disassembling the unit.
The backcover is installed.

Adding Expansion Cards

The maximum depth for all expansion slots is 11". The PSXX-2/PCXX-2/RSXX-2/RCXX-2 will support up to three PC/104 expansion cards. The PSXX-3/PCXX-3/RSXX-3/RCXX-3 will support any of the following options:

- Three ISA cards
- Two ISA cards and one PCI card

The PSXX-4/PCXX-4/RSXX-4/RCXX-4 will support any of the following options:

- Three PCI cards
- Two PCI cards and one ISA card

Note The PC/104 connector and the ISA or PCI's riser card will support either 5V or universal-type expansion cards. They will not support 3.3V cards.

As with most ISA-bus computer port addresses, 300 through 31F are available for expansion cards. See *I/O Addresses and IRQs on page 30* for a list of the addresses and IRQs used by the PowerStation PS Series. Make sure that any cards you install do not conflict with these IRQs or addresses.

Adapter cards supported by Interact

If you have a PowerStation (PS or RS), the following table lists PLC expansion cards that can be used with Interact software and the address range for each card.

- Do not put all cards at the same address.
- In all cases, use the highest address location possible. This will provide contiguous memory for applications.

Driver Name	Address Range	Space Required	Memory Boundary
Allen-Bradley Remote I/O (ABREMIO)	C800 - DFFF	32K	Resides on 32K boundaries
CTC Parker Automation MachineLogic Control Adapter (MLCA)	C800 - DFFF	4, 8, 16, or 32K	Dependent upon "Space Required"
DCSNET PC Link Module (DCSNET)	A000 - FC00	16K	Resides on 16K boundaries
Device Net (DVNT)		16K	Resides on 16K boundaries
GE Fanuc Genius I/O (GENIUS)	C800 - E000	16K	Resides on 16K boundaries
Giddings & Lewis (GLP9)	C000 - E180	2K	Resides on 2K boundaries
Mitsubishi A7BDE (MITS) - MELSECNET and A3N	C800 - DFFF	16K	Resides on 16K boundaries

Driver Name	Address Range	Space Required	Memory Boundary
Mitsubishi A7BDE (MITS) - RS4	C800 - DFFF	8K	Resides on 8K boundaries
Modicon ModBus Plus (MBPL)	C800 - DFFF	2K	Resides on 2K boundaries
OMRON SYSMAC Link (SLNK)	C000 - D800	2K	Resides on 2K boundaries
Opto 22 (MIST)	C000 - E180	2K	Resides on 2K boundaries
Reliance R-NET PC Link Module (RLNT)	C800 - DFFF	16K	Resides on 16K boundaries
Siemens TIWAY (TIWAY)	C000 - E000	4K	Resides on 4K boundaries
Square D SY/MAX Module (SDSL)	CA00 - D300	4K	Resides on 4K boundaries
Sutherland-Schultz SD Adapter (SSSD)	C800 - DFFF	32K	Resides on 32K boundaries
Texas Instruments Remote I/O (TIRIO)	C800 - DFFF	1K	Resides on 1K boundaries

Plug and Play configuration

If you add an expansion card that is not configured for plug and play (a “legacy” card), you must configure your system in order to avoid resource conflicts:

To reconfigure your system for a legacy expansion card, complete the following steps:

1. Turn on the PowerStation, and before the system boots, press the **F2** key on your keyboard.

The CMOS Setup Utility screen will appear.

2. Using the right arrow key, tab to the **Advanced** menu.
3. Arrow down to **PNP\PCI Configuration** and press **Enter**.

The PNP/PCI Configuration screen will appear.

4. On the PNP/PCI Configuration screen, be sure that **Resources Controlled By** is set to **Manual**.
5. If necessary, use the Down Arrow key to tab to **Resources Controlled By** and the Page Up and Page Down keys to change the setting to **Manual**.
6. Use the Down Arrow key to tab to **IRQ used by the Legacy card**.
7. Use the Page Up and Page Down keys to change **PCI/ISA PnP** to **Legacy ISA**.
8. Press **Esc**.
9. Press **Esc**.

The Save to CMOS and Exit prompt will appear.

10. Select **Y**, and then press **Enter**.

Your settings will be saved to CMOS, and you will exit the CMOS Setup Utility.

Changing Jumper Settings

Like other PCs, the PowerStation PS uses jumpers to control some system functions. This section explains how to change jumper settings in order to:

- Enable or disable the Ethernet port
- Change the communication protocol for COM2
- Change the master/slave status of the system's CF drives
- Clear the system's CMOS settings



Important Other jumpers, including those for the touchscreen IRQ and address, have been factory set for optimal system performance and should **not** be changed.

Jumper locations

Locations of the PowerStation's configurable jumpers are shown in the illustration below.

CPU Card and Configurable Jumpers

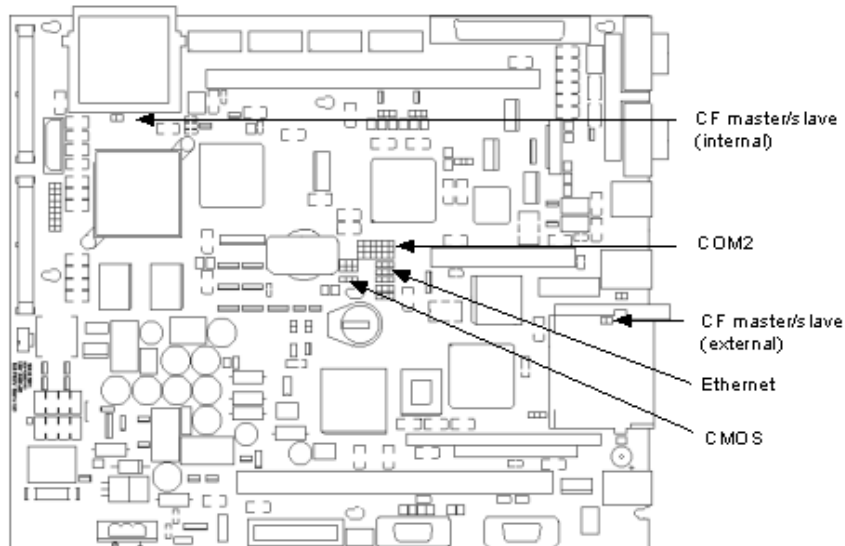

To change jumper settings, first open the backshell (see *Opening the system on page 66* for instructions). Then follow the procedures outlined in this section. Jumpers set to “on” and “off” should look like those shown below.

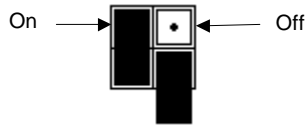

Note “Off” jumpers can be completely removed or placed as in the illustration above.

Ethernet port

The **ENET** jumper controls the Ethernet port (see the configurable jumpers illustration on page 71 for this jumper’s location). The default setting, with the Ethernet port enabled, is shown below.

Enabled (default)

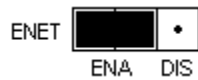

To disable the Ethernet port, set the jumper as shown below.

Disabled



COM2 communication protocol

Jumpers that set the communication protocol for COM2 are shown in the configurable jumpers illustration on page the previous page. The default protocol for COM2 is RS-485. Jumper settings for this protocol are shown in the following illustration.

RS485

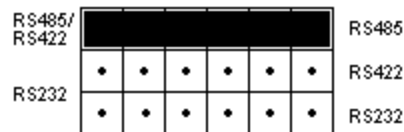

If you want the protocol to be RS422, set the jumpers as shown below.

RS422

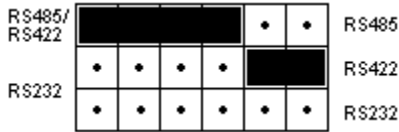

If you want the protocol to be RS232, set the jumpers as shown in the illustration on the following page.

RS232

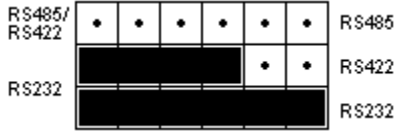

Note See also *Serial Ports* on page 22. For pinout information on all three serial ports, see on page *COM1, 2, and 3 pinouts* on page 23.

Internal CF master/slave status

Jumpers **E7** and **E8** determine whether the internal CF card operates as a master or slave drive. The location of these jumpers is shown on page 71.

Note The internal Compact Flash will compete with the hard drive as master or slave. You will need to set a designation.

When the internal CF is the master drive, the jumpers are “On,” as shown in the following illustration.

Master



When the internal CF is a slave, the jumpers should be “Off,” as shown below.

Slave



External CF master/slave status

Jumpers **E70** and **E71** determine whether the external CF card operates as a master or slave drive. The location of these jumpers is shown in the illustration on page 71.

Note The external Compact Flash will compete with the CD ROM drive as master or slave. You will need to set a designation.

When the external CF is the master drive, the jumpers are “On,” as shown below.

Master

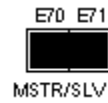

When the external CF is a slave, the jumpers should be “Off,” as shown below.

Slave

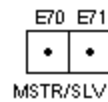

CMOS settings

Jumpers **E52**, **E53**, and **E54** enable you to clear the computer’s CMOS settings. The location of these jumpers is shown in the illustration on page 71. The default setting for these jumpers is shown below.

Default

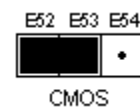

To clear the CMOS settings, complete the following steps:

1. Set the jumpers as shown below.

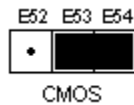

2. Wait a few seconds.
3. Reset the jumpers to the default settings.

Troubleshooting

This section provides basic troubleshooting steps to help you identify and correct problems that you may have with your PowerStation PS Series. Each problem is described, followed by one or more possible solutions. Begin with the first solution, and continue until you have solved the problem or exhausted the possible solutions.

If you cannot solve the problem yourself, or if you have a problem that is not documented here, contact your CTC Parker distributor or our Technical Support department at 513-248-1714.

Use the following table to find discussions of specific problems.

Problem	Page
Problems When Starting	
System does not start; the display is blank.	76
The RAM test fails, or the total memory installed does not match the total contiguous RAM listed in the display following the RAM test.	76
The system locks up while starting and will not restart (PS/PC only).	76
The DOS prompt is displayed instead of the MachineShop Shell main menu (PS/RS only).	77
Autoexec.bat and Config.sys problems (PS/RS only).	78
Problems Signaled by PowerSmart	
An error condition exists for a power supply voltage.	82
An error condition exists for a temperature.	82
PowerSmart display shows a COMM ERROR.	82
Problems with Displays	
The top or bottom half of the screen looks dark.	83
After startup, the touchscreen is blank.	83
Problems with Touchscreens	
After startup, the touchscreen does not work properly, or touchscreen calibration is incorrect.	84
After calibrating the touchscreen, it either does not work or does not follow your finger.	84
Problems with Peripheral Devices	
A PS/2 mouse does not work.	85
A keyboard does not work.	85
The Ethernet port does not work.	85
A driver does not work with the installed adapter card.	85

Problems When Starting

Some of the most common problems that users encounter with PCs occur when they start their systems. This section discusses problems that may occur during startup.

System does not start; the display is blank

1. Turn off the system.
2. Make sure that the power cord is firmly plugged into both the system and the power source.
3. Restart the system.

If the display does not come on, continue with step 4.

4. Turn off the system.
5. Disconnect the system from the power source.
6. Open the backcover, following the procedure in *Opening the system on page 66*.
7. Make sure that the video cable is firmly connected.
8. Make sure that the SDRAM modules are firmly seated in their sockets and that the socket latches are fully engaged.
9. Make sure that all cards are firmly seated.
10. Close the backshell, following the procedure in *Closing the system on page 68*.
11. Reconnect the system to the power source.
12. Restart the system.

The RAM test fails, or the total memory installed does not match the total contiguous RAM listed in the display following the RAM test

Note The CPU board contains 32M of memory. You must add the same amount of memory to the SDRAM stick.

1. Turn off the system.
2. Disconnect the system from the power source.
3. Open the backshell, following the procedure in *Opening the system on page 66*.
4. Re-seat the SDRAM modules on the CPU card.

Make sure that the modules are firmly seated in their sockets and that the socket latches are fully engaged.

5. Close the backshell, following the procedure in *Closing the system on page 68*.
6. Reconnect the system to the power source.
7. Restart the system.

The system locks up while starting and will not restart (PS/RS only).

1. Turn off the system.
2. Connect a keyboard to the system.
3. Restart in MS-DOS mode.
4. When the message Starting MS-DOS appears, press the F8 key.

This will cause the system to step through the Autoexec.bat and Config.sys files line-by-line.

Note If the **Starting MS-DOS** message does not appear, go to step 7.

See *Autoexec.bat and Config.sys problems (PS/RS only)* on page 78 for the correct text of both files.

- In particular, if your system is running on a Compact Flash card, make sure that the memory region used by the CF card is excluded (with the **X/=** parameter) when loading **emm386.exe**.
- Remove or correct the offending line in the Config.sys or Autoexec.bat file.

Note Use the **DOS copy** command to overwrite the corrupted file, as described on page 81.

5. Step through the Autoexec.bat and Config.sys files until you find the cause of the lockup.
6. Restart the system to see if the problem has been solved.
7. If the system locks up before the Starting MS-DOS message appears, restart the unit, and press the F2 key to enter the BIOS setup program.
8. In the Exit menu, select the Load Setup Defaults option.
9. Selecting this option will restore the BIOS settings to their factory default configuration.
10. In the Advanced menu, change the Reset Configuration Data to Yes.
11. When the system restarts, this setting will automatically switch back to No.
12. Save these settings, and exit the setup program.
13. Restart the system.

The DOS prompt is displayed instead of the MachineShop Shell main menu (PS/RS only).

1. If the system appears to be operating correctly otherwise, restart it.
2. If the problem persists, turn off the system.
3. Connect a keyboard to the unit.
4. Restart the system.
5. When the message **Starting MS-DOS** appears, press the **F8** key.

This will cause the system to step through the Autoexec.bat and Config.sys files line-by-line.

6. The Autoexec.bat file may have been corrupted or modified. Compare the lines in the Autoexec.bat file with the correct text, contained in *Autoexec.bat and Config.sys problems (PS/RS only)*, on page 78.
7. Remove or correct the offending line.

Note Use the **DOS copy** command to overwrite the corrupted file, as described on page 81.

8. Verify that the following lines (which load the MachineShop Shell) appear at the end of the Autoexec.bat file and do not have the word **REM** in front of them:

```
CD \CTC
PSU
```

9. Restart the system.

Autoexec.bat and Config.sys problems (PS/RS only)

In the (PS/RS only), some startup problems might be caused by a corrupted or modified Autoexec.bat or Config.sys file. Backup copies of these files (Autoexec.ctc and Config.ctc) are included on the PowerStation Start Disk (KA-83109) shipped with your system.

The correct text for the Autoexec.bat and Config.sys files is shown below. Compare your Autoexec.bat and Config.sys files to these models.

Autoexec.bat Files

```
@ECHO OFF
REM*****
REM PowerStation Autoexec.bat file
REM Copyright (c)1999 CTC Parker Automation
REM*****

PROMPT $p$g
SET TEMP=C:\DOS
SET TOUCH_ADDR=3E8
SET TOUCH_IRQ=11
PATH C:\;C:\DOS;C:\CTC

REM*****
REM Install PowerStation Special Functions if not
REM running on a P1.
REM*****

C:\CTC\IDPWR -T -S
IF ERRORLEVEL 3 GOTO ITSAP1
LH C:\CTC\BIOSTSR

REM*****
REM If an external mouse is connected, MOUSE will
REM install successfully and create a new MOUSE.INI
REM file.
REM*****

CD \CTC
IF EXIST C:\CTC\MOUSE.INI DEL C:\CTC\MOUSE.INI
LH C:\CTC\MOUSE

:ITSAP1

REM*****
```

```

REM Load VESA TSR if not already supported by the video REM system.
REM*****

C:\CTC\IDPWR -V -S
IF NOT ERRORLEVEL 1 GOTO YESVESA
LH C:\CTC\VESA
:YESVESA

REM*****
REM Load the MachineLogic Control Adapter driver if it REM is present.
REM*****

IF NOT EXIST C:\MACHLOG\NUL.EXT MD C:\MACHLOG
CD \MACHLOG
IF NOT EXIST C:\CTC\MLCA.EXE GOTO NOMLCA
CD \CTC
LH C:\CTC\MLCA

:NOMLCA

REM*****
REM Initialize touchscreen drivers.
REM*****

SET TOUCH_PATH=C:\TOUCH
CALL %TOUCH_PATH%\TCHINIT.BAT

REM*****
REM Set up Interact and MachineLogic environment
REM variables for MS Shell.
REM*****

SET INTERACT=C:\INTERACT
SET INTERACT_FILES=C:\INTERACT\APPFILES
SET INTERACT_STARTUP=C:\STARTUP
SET MACHINELOGIC=C:\MACHLOG

REM*****
REM Load NETWORK drivers -- NOVELL and/or TCPIP stack.
REM Remove REM on the CALL statement to load NOVELL
REM network batch file. If used, this must be called
REM BEFORE loading the TCPIP stack.
REM*****

CD \NET
REM CALL C:\NET\NET.BAT
LH C:\NET\TCPIP

REM*****
REM Load CD-ROM driver
REM*****
LH C:\DOS\MSCDEX.EXE /D:TEAC_CDI /M:15

```

```

REM*****
REM Load MachineLogic if ML kernel present, and set for REM boot
operation (determined by MLDU.EXE return value REM 0 = ENABLED, 1 =
DISABLED)
REM*****

IF NOT EXIST C:\MACHLOG\NUL.EXT MD C:\MACHLOG
CD \MACHLOG
IF NOT EXIST C:\MACHLOG\MACHLOG.EXE GOTO NOML
C:\CTC\MLDU
IF ERRORLEVEL 1 GOTO NOML

C:\MACHLOG\RTXDOS
C:\MACHLOG\MACHLOG

:NOML

REM*****
REM Call AUTOEXEC.BAT file contained in project, if it
REM exists.
REM*****

IF NOT EXIST C:\STARTUP\NUL.EXT MD C:\STARTUP
CD \STARTUP
IF EXIST C:\STARTUP\AUTOEXEC.BAT CALL C:\STARTUP\AUTOEXEC.BAT

REM*****
REM Start the MachineShop Shell.
REM*****

CD \CTC
PSU

```

Config.sys Files

```

;MS-DOS V6.22, EMM386.EXE V4.49
SHELL=C:\COMMAND.COM /E:1024 /P
FILES=30
BUFFERS=30
STACKS=9,256
DEVICE=C:\DOS\HIMEM.SYS
REM
REM MachineLogic uses the High Memory Area (HMA) to
REM store all I/O and variable data. Therefore, DOS
REM should be loaded entirely into conventional memory. REM If Machine
REM Logic is not being used, then DOS should REM be loaded HIGH into the HMA
to conserve conventional REM memory.To load DOS HIGH use DOS=HIGH,UMB -
REM otherwise use DOS=LOW,UMB.

REM DOS=HIGH,UMB
DOS=LOW,UMB
REM
REM                                     !!! NOTE !!!
REM EMM386 can be used to free up more conventional
REM memory for use by MachineLogic and Interact, by

```

```

REM allowing TSRs to be loaded high.
REM Just remove the word REM in front of the appropriate REM command, and
REM adjust the parameters as required for REM your system's configuration.
REM
REM If EMM386 is used, any upper (UMB) memory used by
REM adapter cards must be excluded with the "X="
REM parameter, as shown in the example below. This
REM example is for a MachineLogic Control Adapter at
REM address D800, configured to use 4KB of NVRAM (the
REM factory default).
REM Please adjust the "X=" parameter to match your REM REM system
REM configuration.
REM
REM DEVICE=C:\DOS\EMM386.EXE NOEMS NOVCPY X=D800-D8FF
REM
REM The following settings can be used on a system using REM the SST
REM Profibus ISA I/O adapter (D000-D7FF), with REM the MachineLogic Control
REM Adapter configured to
REM provide 32KB of NVRAM (D800-DFFF).
REM
REM DEVICE=C:\DOS\EMM386.EXE NOEMS NOVCPY X=D000-DFFF
REM
REM On a P1 PowerStation, the range C800 through CFFF REM must be
REM excluded and the E000-EFFF range must be
REM explicitly included. Use the following command for REM loading EMM386
REM on a P1.
REM
REM DEVICE=C:\DOS\EMM386.EXE NOEMS NOVCPY X=C800-CFFF
REM X=D800-D8FF I=E000-EFFF
REM
REM IMPORTANT: Always include the NOEMS and NOVCPY
REM switches when using EMM386 with MachineLogic and
REM Interact.
REM
REM Load the Teac CD-ROM driver for DOS
REM
DEVICEHIGH=C:\CDROM\TEAC_CDI.SYS /D:TEAC_CDI

```

If you suspect a problem with the Autoexec.bat or Config.sys file, use the **DOS copy** command to create a backup copy of your current file. Then overwrite the suspect file with the backup. For example, if the Autoexec.bat file is suspect, type the following commands at the DOS prompt:

```

copy autoexec.bat autoexec.old
copy \ctc\autoexec.ctc autoexec.bat

```

Problems Signaled by PowerSmart

The PowerStation PS Series comes with the exclusive PowerSmart system monitor that keeps track of the unit's power supply output voltage, internal temperature, and hours of operation. It also signals communication errors by any of PowerSmart's monitoring devices. See *PowerSmart* on page 28 for information about how the PowerSmart utility works.

The following table shows the values monitored by PowerSmart.

Parameter	Nominal Value	Minimum Value	Maximum Value
Internal temperature	N/A	N/A	65°C
3.3V power supply	3.3 VDC	3.0 VDC	3.6 VDC
5V power supply	5.0 VDC	4.75 VDC	5.5 VDC
12V power supply	12.0 VDC	11.5 VDC	12.5 VDC
-5V power supply	-5.0 VDC	-5.5 VDC	-4.75 VDC
-12V power supply	-12.0 VDC	-12.5 VDC	-11.5 VDC

- If any of the system's voltage or temperature parameters is out-of-limit, the PowerSmart display will change color, and the gauges will show the error condition.
- If the display has been minimized, the PowerSmart button on the Windows taskbar will flash continually.
- Click the button to show the display.

The remainder of this section explains how to respond if PowerSmart indicates that any parameters are out of limit.

An error condition exists for a power supply voltage

1. If the power supply shows low voltage, make sure that any expansion cards installed do not exceed the recommended power supply load limit (see *Electrical Specifications on page 94* for this parameter).
2. Use a voltmeter to measure the power supply.
3. If the voltmeter confirms the error, contact our Technical Support department at 513-248-1714 about replacing the power supply.

An error condition exists for a temperature

1. Make sure that any expansion cards installed do not exceed the recommended power supply load limit (see *Electrical Specifications on page 94* for this parameter).
2. Make sure that the maximum rated ambient temperature for the system has not been exceeded (see *Environmental Specifications on page 93* for this parameter).

The PowerSmart display shows a COMM ERROR

- When a communications error occurs in a monitoring device, the **Comms Status** light in the PowerSmart display will change from green to red, and a dialog box, like the one below, will appear describing the error. Information provided by the device will not display.



- If the microcontroller fails, no information will display on any gauge because the microcontroller decides what information to display.

Note If the Comms Status light is red, but no dialog box appears, click on the light to see the COMM ERROR.

1. Check for loose or shorted pins on the PowerSmart peripheral device showing the error.

The devices and their locations are shown below. See *PowerSmart* on page 28 for a description of the devices' functions.

Device	Location
Microcontroller (87LPC764)	U38
Peripheral monitor (DS1780)	U41
Temperature monitor (LM 75)	
EEPROM (24C02)	U39

2. Contact our Technical Support department at 513-248-1714 about replacing the device showing the error.

Problems with Displays

The top or bottom half of the screen looks dark

- One of the backlight bulbs may be burned out. Replace both backlight bulbs.

Contact your CTC Parker distributor or CTC Customer Support to order a Backlight Bulb Replacement Kit.

After startup, the display is blank

- If the system appears to be operating correctly otherwise, restart the system.

PS/PC only

1. If the problem persists, turn off the system.
2. Connect a keyboard to the unit.
3. Restart in MS-DOS mode.
4. When the message **Starting MS-DOS** appears, press the **F8** key.

5. This will cause the system to step through the Autoexec.bat and Config.sys files line-by-line.
6. Compare the lines in the Autoexec.bat file with the correct text, contained in *Autoexec.bat and Config.sys problems (PS/RS only) on page 78*.
7. Verify that the following lines appear in the Autoexec.bat file before the lines that load touchscreen driver:

```
IF EXIST C:\CTC\MOUSE.INI DEL C:\CTC\  
MOUSE.INI  
LH C:\CTC\MOUSE
```

8. Verify that the touchscreen drivers are being loaded.

Look in the Autoexec.bat file for the following lines:

```
SET TOUCH_PATH=C:\TOUCH  
CALL %TOUCH_PATH%\TCHINIT.BAT
```

Note Use the **DOS copy** command to overwrite a corrupted Autoexec.bat file, as described on page 81.

9. If you have changed the jumper settings for your touchscreen address or IRQ, locate the following lines near the beginning of the Autoexec.bat file, and change them to reflect your new settings:

```
SET TOUCH_ADDR=3E8  
SET TOUCH_IRQ=11
```

Problems with Touchscreens

This section discusses problems that may occur in systems that have a touchscreen display. If you do not have a touchscreen, skip this section.

After startup, the touchscreen does not work properly, or touchscreen calibration is incorrect

- You may need to reconfigure or recalibrate the touchscreen.

See *Reconfiguring the Touchscreen Driver on page 60* and *Recalibrating the Touchscreen on page 62* for instructions.

After calibrating the touchscreen, it either does not work or does not follow your finger

1. Open the unit following the procedure on page 66.
2. Make sure that the touchscreen cable is properly connected.
3. Close the unit following the procedure on page 68.
4. If the touchscreen cable is damaged, replace the touchscreen cable.

Contact our Technical Support department at 513-248-1714 for information about purchasing a replacement.

Problems with Peripheral Devices

This section discusses problems that may occur after startup.

A PS/2 mouse does not work

1. Make sure that you are using a Microsoft PS/2 mouse.
Some PS/2 mice that claim to be Microsoft-compatible will not work correctly with the PS/PC. Do not use a serial mouse with a serial-to-PS/2 port adapter.
2. Make sure that your mouse is plugged into the PS/2 mouse port.
3. Try using a new PS/2 mouse.

A keyboard does not work

1. Make sure the keyboard is an AT-compatible keyboard, not an XT keyboard.
2. Make sure that your keyboard is plugged into the PS/2 keyboard port.
3. Try using a new keyboard.

The Ethernet port does not work

1. Make sure that the Ethernet cable is securely plugged into the Ethernet port.

PS/PC only

1. If the problem persists, turn off the system.
2. Connect a keyboard to the unit.
3. Restart in MS-DOS mode.
4. When the message Starting MS-DOS appears, press the **F8** key.

This will cause the system to step through the Autoexec.bat and Config.sys files line-by-line.

5. Make sure that the networking software is being loaded.

Specifically, verify that the following lines appear in the Autoexec.bat file and do not have the word **REM** in front of them:

```
CD \NET
CALL C:\NET\NET.BAT
```

A driver does not work with the installed adapter card

- Make sure that there are no interrupt or memory conflicts with other adapter cards.
See *Adding Expansion Cards* on page 69 for a list of I/O addresses available to expansion cards. See *I/O Addresses and IRQs* on page 30 for the addresses and IRQs used by the system.

PS/PC only

- Make sure that the adapter card is supported by the PS/PC.

See *Adding Expansion Cards on page 69* for a list of adapter cards that the PowerStation PS series will support and their memory locations.

Note For additional information about adapter cards supplied by CTC Parker, see the Windows help file for your Interact device driver(s) or your I/O driver help file(s). These help files will be accessible from the MachineShop toolbar).

APPENDIX A: SPECIFICATIONS

This appendix lists specifications for all models in the PowerStation PS Series unless otherwise indicated.

Contents

- Physical Specifications*..... 88
- Recommended SDRAM Manufacturers*..... 91
- Operating Systems Supported*..... 91
- Display Specifications* 92
- Environmental Specifications*..... 93
- Electrical Specifications*..... 94
- Testing Specifications* 94
- Faceplate Chemical Resistance* 95
- Agency Approvals* 96

Physical Specifications

Category	Specifications
Dimensions (H x W x D)	<ul style="list-style-type: none"> 9.5"/10.4" display unit: XXXXX 12.1" display unit: 12.1" x XXXXX"x XXXXX" (307.3mm x XXXXXmm x XXXXXmm) 15" display unit: 13.3" x XXXXX" x XXXXX" (337.8mm x XXXXXmm x XXXXXmm)
Weight	<ul style="list-style-type: none"> 9.5" display unit: XXXXX 10.4" display unit: XXXXX 12.1" display unit: XXXXX lbs. 15" display unit: XXXXX lbs.
Processor	<ul style="list-style-type: none"> Intel® Pentium MMX™ 266MHz, 66MHz host bus frequency
Memory	<ul style="list-style-type: none"> 32MB SDRAM (4 chips) is soldered on the CPU card. In addition, one DIMM socket supports up to 256MB of SDRAM. <hr/> <p>Note A minimum of 128MB SDRAM is recommended for systems running Windows 2000. If you need to replace SDRAM, see <i>Recommended SDRAM Manufacturers on page 91</i>.</p>
Cache	512K level-two cache
Storage	<ul style="list-style-type: none"> 3.2GB or higher hard drive (optional) 24X CD-ROM drive (optional) 1.44MB high-density floppy drive (optional, external) Two on-board Compact Flash (CF) slots. External CF slot has CF card ejector
Peripheral interfaces	<ul style="list-style-type: none"> Three 16550 serial ports <ul style="list-style-type: none"> Two 9-pin serial RS232 ports One 9-pin RS232/422/485 configurable port One internal for the touchscreen controller One 25-pin bi-directional parallel port, supports SPP, EPP, and ECP Two PS/2 ports <ul style="list-style-type: none"> Keyboard Mouse Two USB ports <hr/> <p>Note DOS and Windows NT 4.0 do not support USB ports</p> <ul style="list-style-type: none"> Support for UHCI interface and uses UHCI-compatible software drivers Self-identifying peripherals can be plugged in while the computer is running Automatic mapping of function to driver and configuration Support for isynchronous and asynchronous transfer types over the same set of wires Support for up to 127 physical devices Guaranteed bandwidth and low latencies appropriate for

Category	Specifications
	<p>telephony, audio, and other applications</p> <ul style="list-style-type: none"> • Error-handling and fault-recovery mechanisms built into the protocol • One RJ45 Ethernet port, 10Base-T/100Base-TX (See “Ethernet Controller” below) • Video port (see “Video” in this table, below”) • Integrated, dual-channel EIDE interface • Support for up to four IDE devices • PIO Mode 4 transfers at up to 16MB/sec • Support for Ultra DMA/33 synchronous DMA mode transfers at up to 33MB/sec • Bus master mode with an 8 x 32-bit buffer for bus master PCI IDE burst transfers • On-board resistive touchscreen controller
Ethernet Controller	<ul style="list-style-type: none"> • Intel 82559 PCI 10BASE-T/100BASE-TX Interface Ethernet controller • RJ45 interface <ul style="list-style-type: none"> • Integrated IEEE 802.3 10BASE-T and 100BASE-TX compatible PHY • System Management Bus (SMB) support for advanced management support • PCI power management specifications compliance • Full duplex support at both 10 and 100 Mbps operation • IEEE 802.3u auto-negotiation support • 3K Transmit FIFO and 3K Receive FIFO • Back-to-back transmission support with minimum interframe spacing • IEEE 802.3x 100BASE-TX Flow Control support\
Video	<ul style="list-style-type: none"> • Intel, CHIPS 69000 HiQVideo™ Accelerator • 2MB of high-speed SDRAM on chip-frame buffer • Intel, CHIPS 69030 optional with 4MB of on-chip memory • Analog video is supported via an industry-standard SVGA 15-pin Sub-D connector located on the rear panel
Touchscreen	<ul style="list-style-type: none"> • A serial touchscreen controller is used to interface to the Touchscreen • The touchscreen is connected to the ISA bus through the 16C552 UART, designated as COM4 • I/O resources for the touchscreen are BIOS • The IRQ choices are IRQ3, IRQ4, IRQ9, IRQ11
Expansion slots	<ul style="list-style-type: none"> • PC/104 expansion up to three cards • ISA PCI riser card connector for expansion up to three ISA or three PCI with three PCI masters • ISA bus—16-bit, supports the IEEE ISA standard, up to 8.333MHz • PCI bus (rev. 2.2)—supports the 33MHz 32-bit, PCI bus architecture

Category	Specifications
BIOS	<p>Phoenix BIOS is located in the 256K boot-block FLASH EPROM. Standard features include:</p> <ul style="list-style-type: none"> • FLASH/EPROM-based setup utility • Power-On Self-Test (POST) • Password protection • Advanced Power Management • System plug and play support
Additional Features	<ul style="list-style-type: none"> • Real-time clock with battery backup • APC (Advanced Power Supply) control • Integrated 24VDC-input power supply • CTC Parker's software security key socket • CTC Parker's PowerSmart hardware support • Beeper • Watchdog Timer <ul style="list-style-type: none"> • Includes a software-enabled/disabled watchdog timer • Generates a system reset when triggered • Timeout interval ranges from 1 to 62 seconds • Can be set by writing an I/O port address

Recommended SDRAM Manufacturers

Available Sizes	Manufacturer	Product Number
256MB	Hyundai	HYM71V653201
256MB	Toshiba	THMY6432G1EG-80
128MB	Hyundai	HYM7V651601BTRG-10S
128MB	Micron	MT8LSDT1664AB-10EB1
128MB	SEC	KMM374S1623BT-GLQ
64MB	Hyundai	HYM7V65801BTRG-10S
64MB	Micron	MT4LSDT864AG-10EB1
64MB	Toshiba	THMY6480F1BEG-80
32MB	Hyundai	HYM7V65401BTRG-10S
32MB	Micron	MT4LSDT464AG-10EC6
32MB	SEC	KMM374S403CT-GL
32MB	SEC	KMM374S823BT-GLQ

Operating Systems Supported

The PS/PC/RS/RC supports the operating systems listed below
MS-DOS 6.xx
Windows 98
Windows 2000
Windows NT 4.0

Display Specifications

Display Options

The PS/PC comes with the display options shown in the following table. Each display can be ordered with or without a touchscreen, and each can show up to 262,144 colors.

PowerStation/PC	Display Size	Resolution	Color	Type
PS10, PC10	*9.5"	VGA	Mono	LCD
	10.4"	VGA	Color	TFT
PS12, PC12	12.1"	VGA	Color	TFT
PS15, PC15	15.1"	XGA	Color	TFT
RS, RC	No display			

*Available with the PS10 model only

Note PSs and PCs with 12.1" and 15.1" displays have a special card installed that enables them to display Interact screens at 640 x 480VGA () resolution.

Brightness, and Backlight Lifetime

Category	Display Type	Specifications
Brightness	9.5" Mono	110 nits
	10.4" TFT Color	200 nits
	10.4" Bright TFT Color	300 nits
	12.1" TFT Color	270 nits (cd/m2)
	15.1" TFT Color	200 nits (cd/m2)
Backlight lifetime	9.5" Mono	10,000 hours
	10.4" TFT Color	50,000 hours
	10.4" Bright TFT Color	25,000 hours
	12.1" TFT Color	30,000 hours
	15.1" TFT Color	50,000 hours

Environmental Specifications

Category	Specifications
Operating temperature	41° to 122° F (5° to 50° C) ambient air temperature
Storage temperature	-4°F to 158°F(-20° to 70° C)
Relative humidity	5% to 95% non-condensing
Altitude	-200ft. to 10,000ft. (-60.96m to 3,048m)
Shock rating	<ul style="list-style-type: none"> • 10g, 11ms operating • 30g, 11ms non-operating
Vibration rating	<ul style="list-style-type: none"> • 0.5g rms from 10 to 500Hz operating • 1.0g rms from 10 to 500Hz non-operating • With CD-ROM drive, 0.25g rms • With Compact Flash card, 1g rms from 10 to 500Hz operating
Faceplate designed for	Type 4/4X environment



Important Limit the system's exposure to adverse conditions, such as dust, oil, moisture, and corrosive vapors in order to minimize maintenance and repair costs.

Remember that the temperature within a protective enclosure is generally higher than the external temperature. Thus, if the system is operating inside an enclosure, at temperature levels above its rated ambient temperature, you must cool the enclosure.

Electrical Specifications

The PowerStation PS Series accepts DC input only. To apply AC power, you must use an AC adapter.

Note You can purchase an AC adapter from CTC Parker Automation at 513-831-2340.

Electrical specifications for the system are listed in the table below.

Category	Unit Specifications
Input voltage	<ul style="list-style-type: none"> 24VDC nominal @ 3.25A Input voltage range: 18VDC-28VDC
Fuse type	<ul style="list-style-type: none"> 250VAC Littelfuse, part #216.315, field-replaceable 5A max. overcurrent protection
Expansion slots	Voltage and total current available for expansion cards are as follows: <ul style="list-style-type: none"> 3.3VDC @ 1A 5VDC @ 1.5A 12VDC @ 0.5A -5VDC @ 0.075A -12VDC @ 0.15A
	<ul style="list-style-type: none">



Important The system's power supply automatically detects the input voltage level and adjusts accordingly. However, always use reliable sources of power, and isolate all communication cables from power lines to enhance noise immunity.

Testing Specifications

Testing Criteria	Classification
Showering arc	NEMA showering arc
Surge withstanding capacitance	IEEE 472-1974
ESD requirements	IEC 801-2
Operating temperature	IEC 68-2-1
Electrical fast transient	IEC 801-4
European Harmonized EAC Standards	EN50082-2, EN55011
Operating vibration	IEC 68-2-6
Mechanical shock	IEC 68-2-27
Random vibration	MIL-STD-810D

Faceplate Chemical Resistance

The system's faceplate can resist the chemicals listed below, with no visible effect.

Acetone	Sulfuric Acid 10%	Motor oil
MEK	Hydrochloric Acid 10%	Gasoline
Toluene	Acetic Acid 10%	Machine oil
Methylene Chloride	Phosphoric Acid	Salad oil
Isopropyl Alcohol	Sodium Hydroxide 10%	Silicone
Xylene	Carbon Tetrachloride	Silicone grease G31
Hexane	Potassium Hydroxide	Kerosene
Butyl Cellosolve	Ammonia water 10%	Gas oil
Cyclohexanone	Sodium Chloride 26%	Silicone oil
Trichloroethylene	Zinc Chloride 81%	Engine oil
Ethanol	Cottonseed oil	Cleanser
Methanol	Glycerin	
Nitric Acid 10%	Grease	

All system surfaces exposed outside of an enclosure are resistive to the following chemicals:

- Commercial glass cleaners
- Ammonia (10% dilute solution)
- Motor oil
- Hydraulic fluid
- Diesel fuel
- Gasoline (leaded, unleaded)
- Silicone-based lubricant
- Alcohol (ethyl, methyl)
- Automatic transmission fluid



Important Sustained exposure to brake fluid or Gunk® brand degreaser can cause damage to monitor materials.

Agency Approvals

All models in the PowerStation PS Series are available with the following combinations of agency approvals:

Agency Approvals			
UL	CUL		
UL	CUL	CE	
UL	CUL	Class 1 Div 2	
UL	CUL	CE	Class 1 Div 2

APPENDIX B: DIMENSIONAL DRAWINGS

This appendix contains dimensional drawings that you can use when installing the PS/PC or the RS/RC. The contents are organized according to the type of system and the display size where applicable.

Contents

<i>Model: PS10-2/PC10-2</i>	98
<i>Model: PS12-2/PC12-2</i>	102
<i>Model: PS15-2/PC15-2</i>	106
<i>Model: PS10-3/PC10-3</i> <i>Model: PS10-4/PC10-4</i>	110
<i>Model: PS12-3/PC12-3</i> <i>Model: PS12-4/PC12-4</i>	114
<i>Model: PS15-3/PC15-3</i> <i>Model: PS15-4/PC15-4</i>	118
<i>Model: RS00-2/RC00-2</i>	122
<i>Model: RS00-3/RC00-3</i> <i>Model: RS00-4/RC00-4</i>	125

Model: PS10-2/PC10-2

To access the complete CAD drawings and 3D models from the CD, complete the following steps:

1. Insert the Industrial PC Drivers and Utilities CD (DCD-1000) into your CD Rom drive if it isn't already in the CD ROM drive.

Note <SrcDir> is the drive where the CD is located. **File** represents the PowerStation drawing that you need.

2. Select <SrcDir>\Documentation\CAD Files\File.

Front View: Monitor

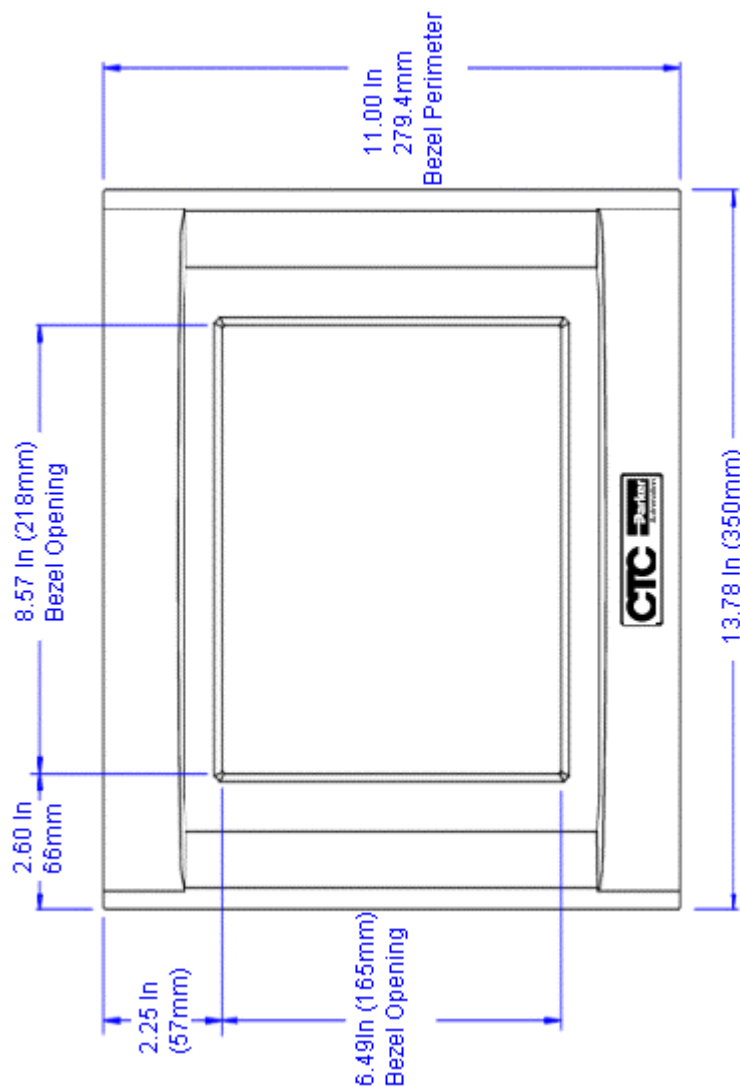

Left Side View: Components

(Model: PS10-2/PC10-2)

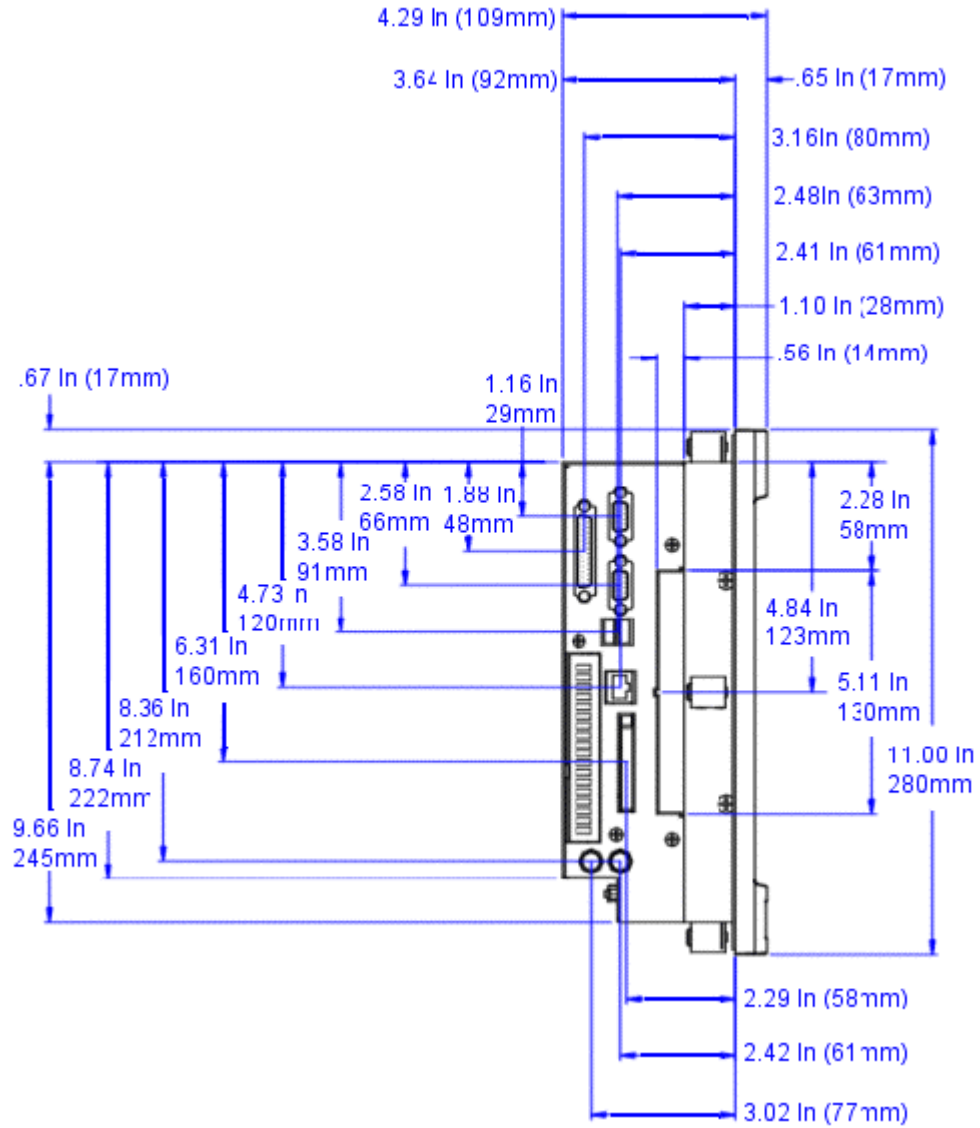

Back View: Components

(Model: PS10-2/PC10-2)

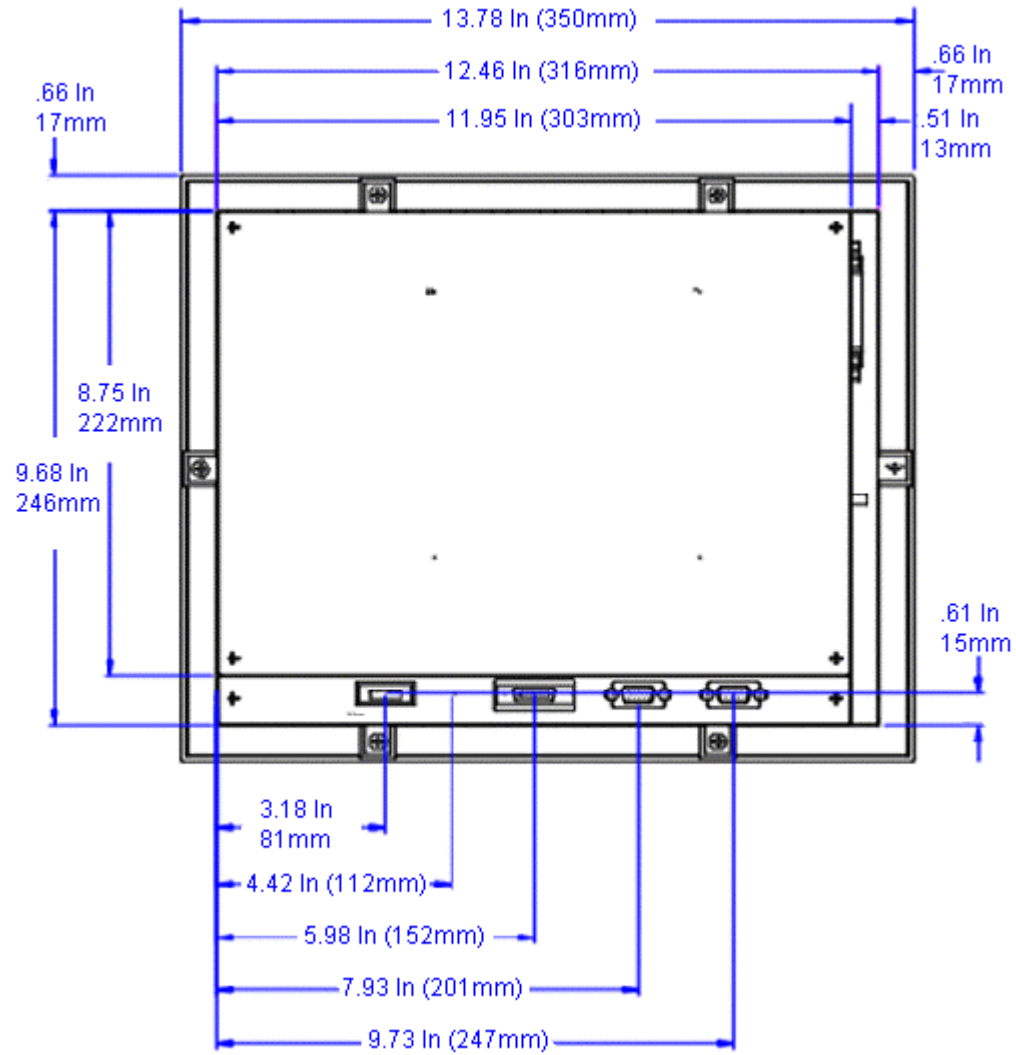

Cutout

(Model: PS10-2/PC10-2)

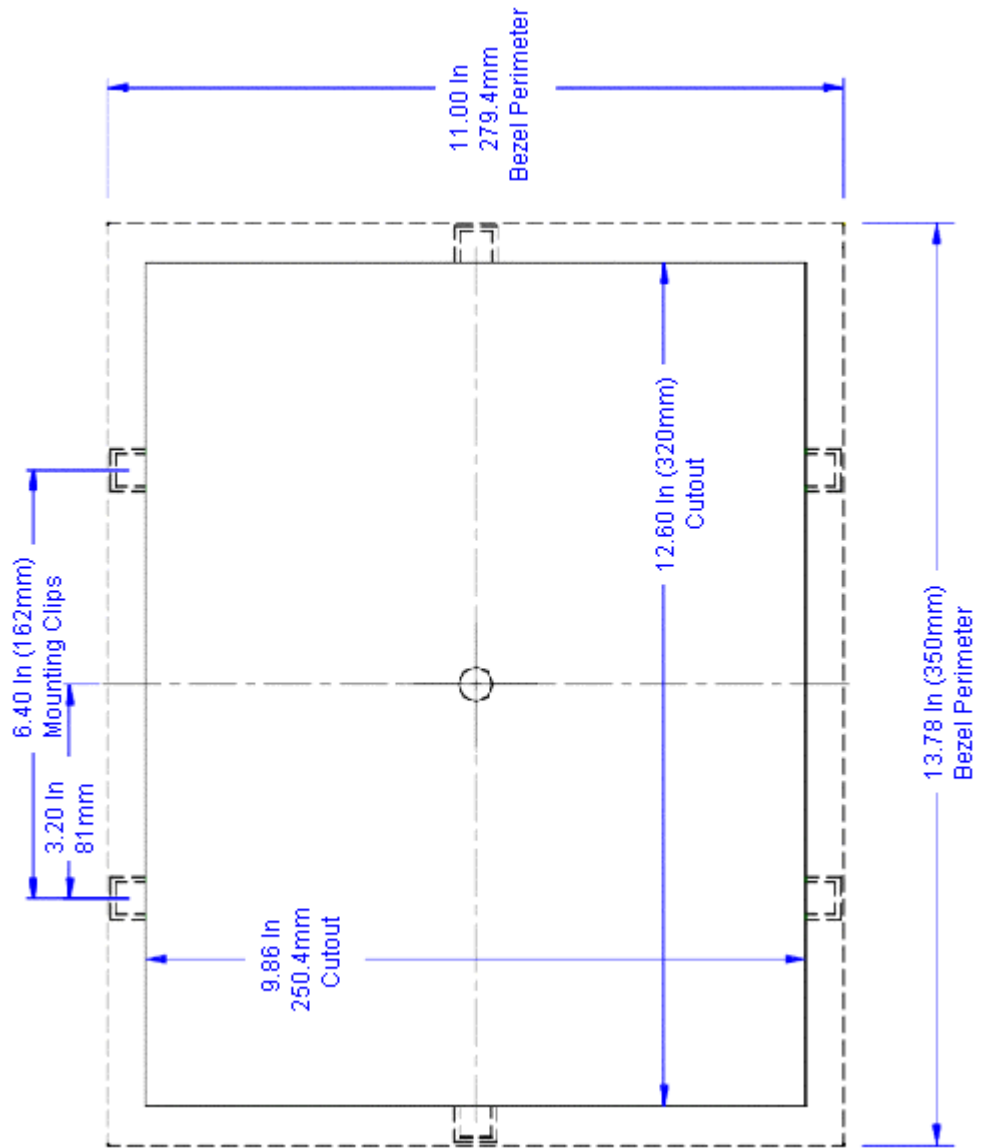

Model: PS12-2/PC12-2

To access the complete CAD drawings and 3D models from the CD, complete the following steps:

1. Insert the Industrial PC Drivers and Utilities CD (DCD-1000) into your CD Rom drive if it isn't already in the CD ROM drive.

Note <SrcDir> is the drive where the CD is located. **File** represents the PowerStation drawing that you need.

2. Select <SrcDir>\Documentation\CAD Files\File.

Front View: Monitor

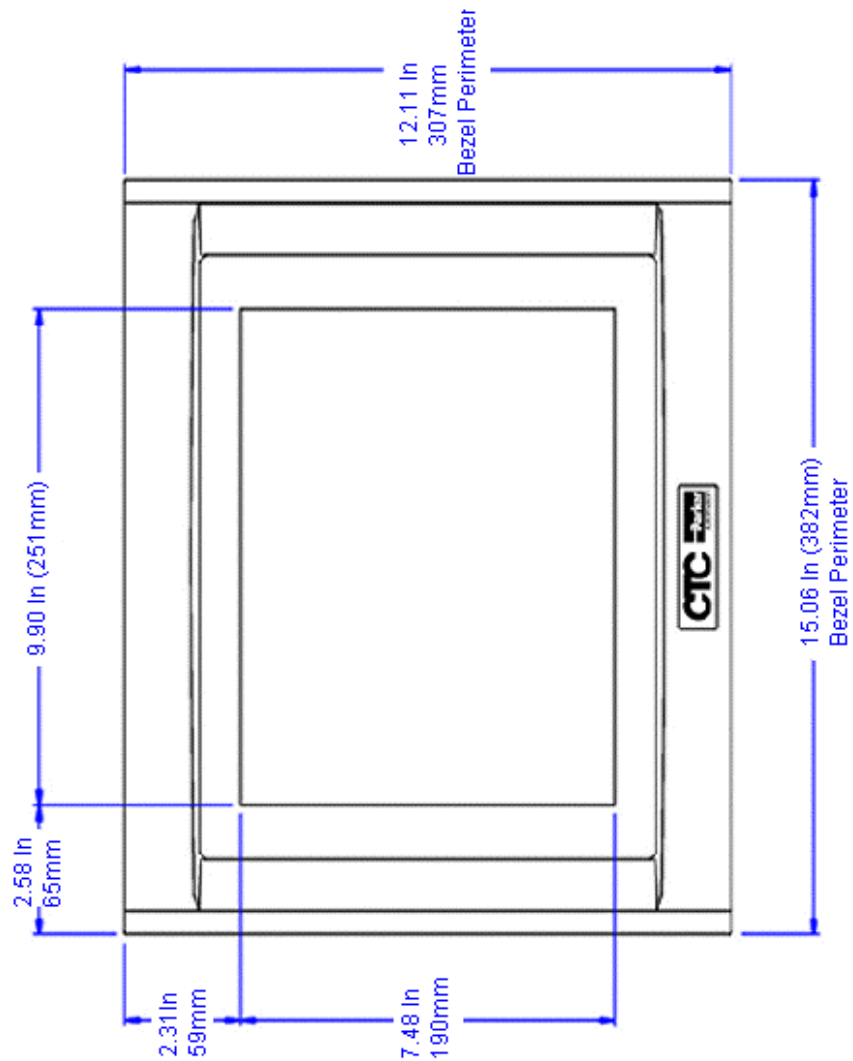

Left Side View: Components

(Model: PS12-2/PC12-2)

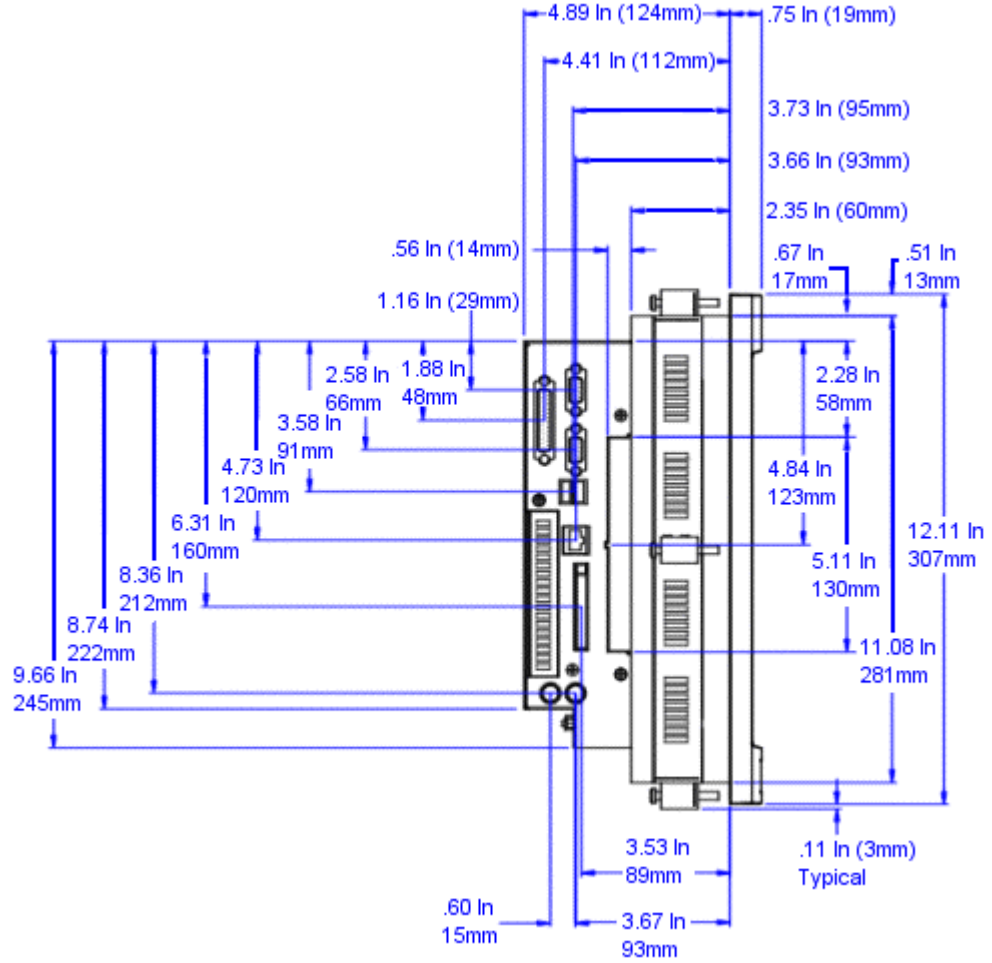

Back View: Components

(Model: PS12-2/PC12-2)

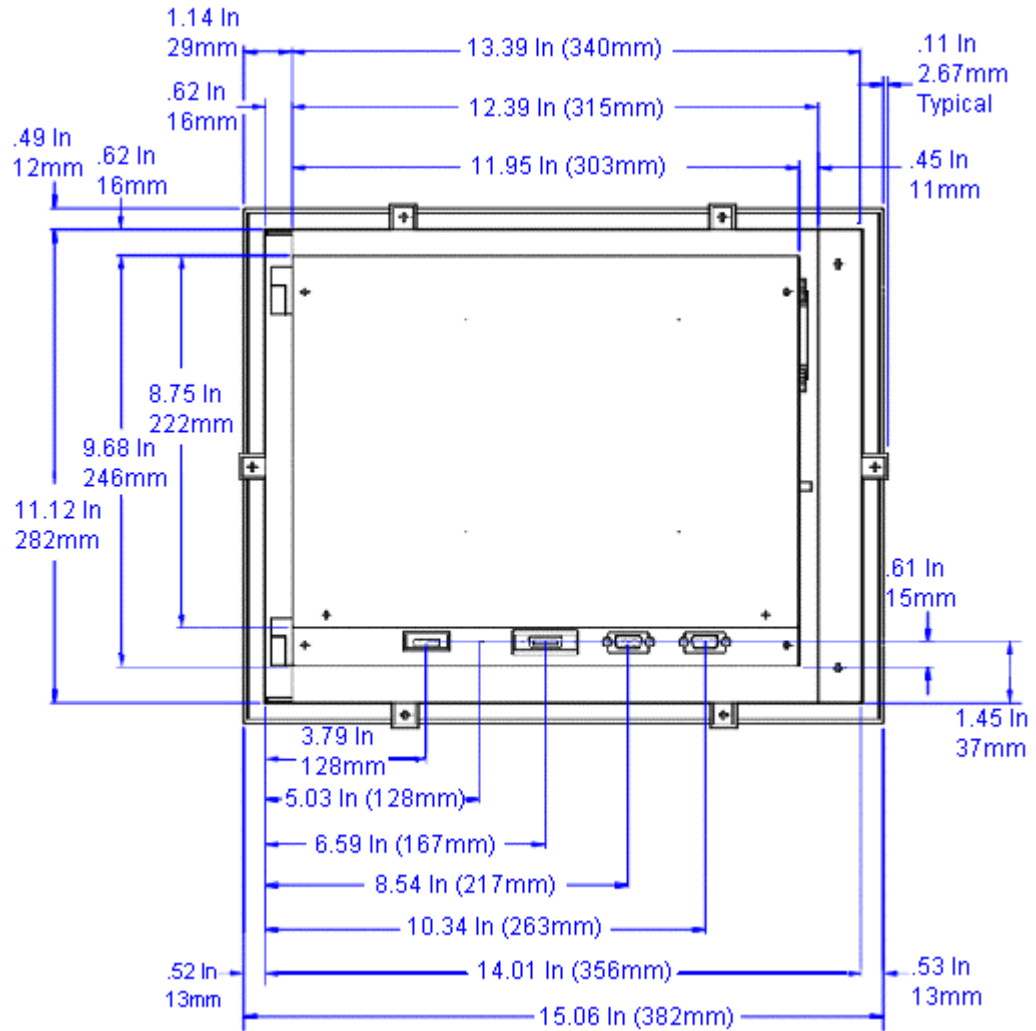

Cutout

(Model: PS12-2/PC12-2)

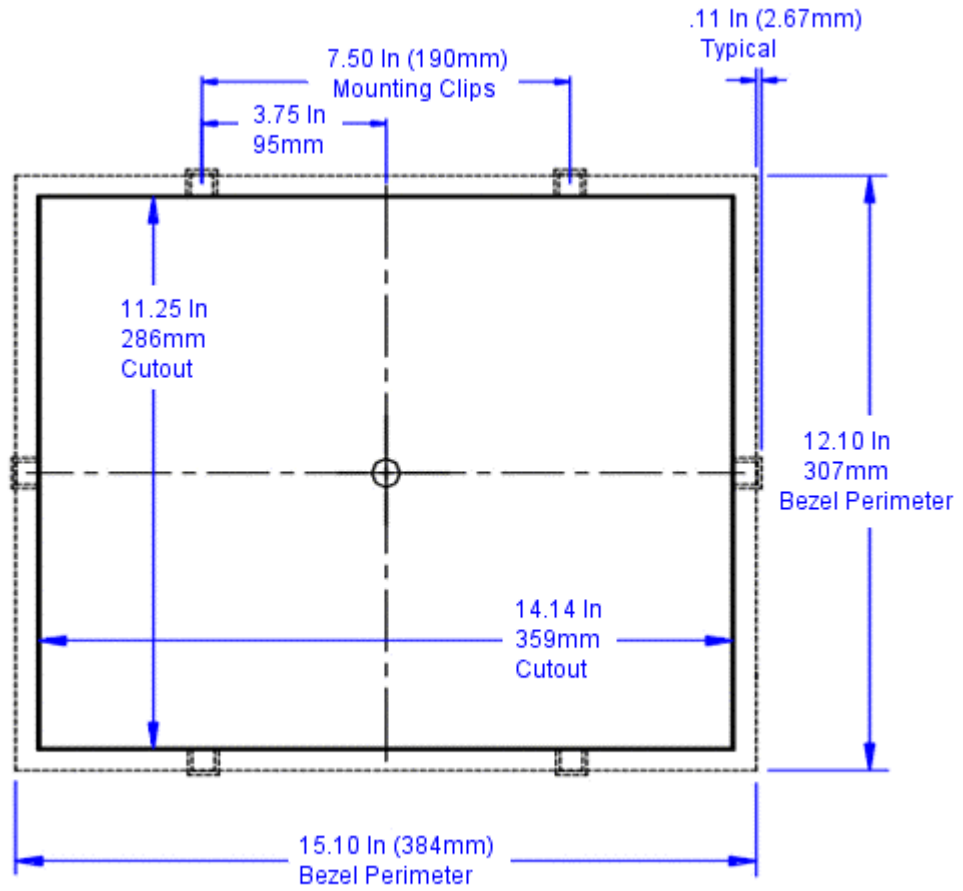

Model: PS15-2/PC15-2

To access the complete CAD drawings and 3D models from the CD, complete the following steps:

1. Insert the Industrial PC Drivers and Utilities CD (DCD-1000) into your CD Rom drive if it isn't already in the CD ROM drive.

Note <SrcDir> is the drive where the CD is located. **File** represents the PowerStation drawing that you need.

2. Select <SrcDir>\Documentation\CAD Files\File.

Front View: Monitor

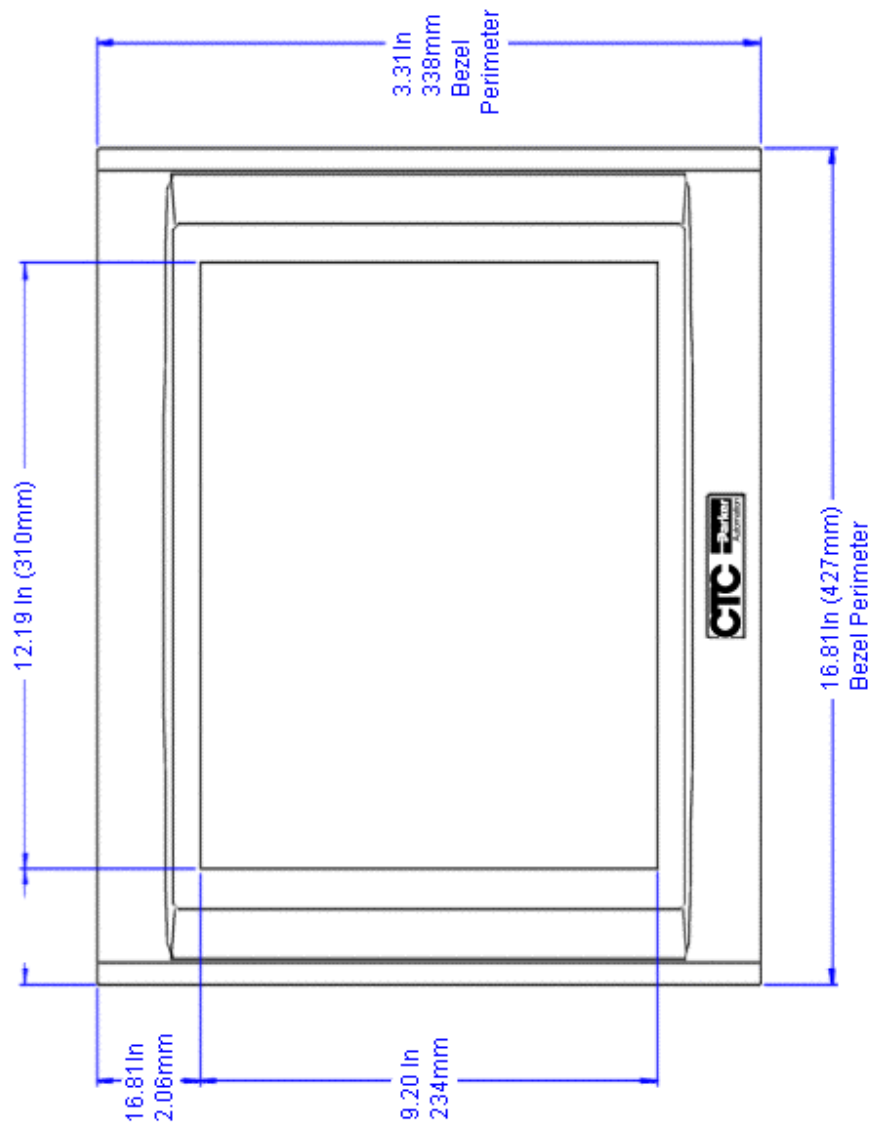

Left Side View: Components

(Model: PS15-2/PC15-2)

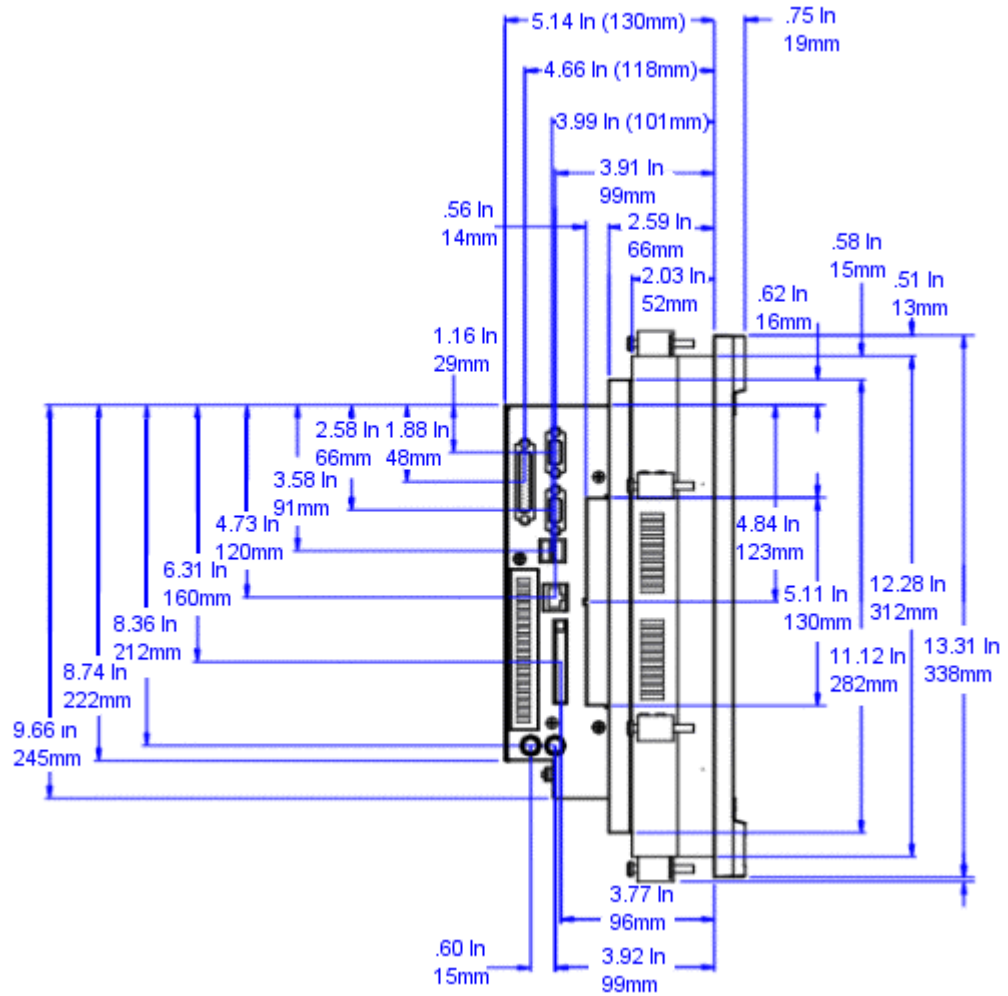

Cutout

(Model: PS15-2/PC15-2)

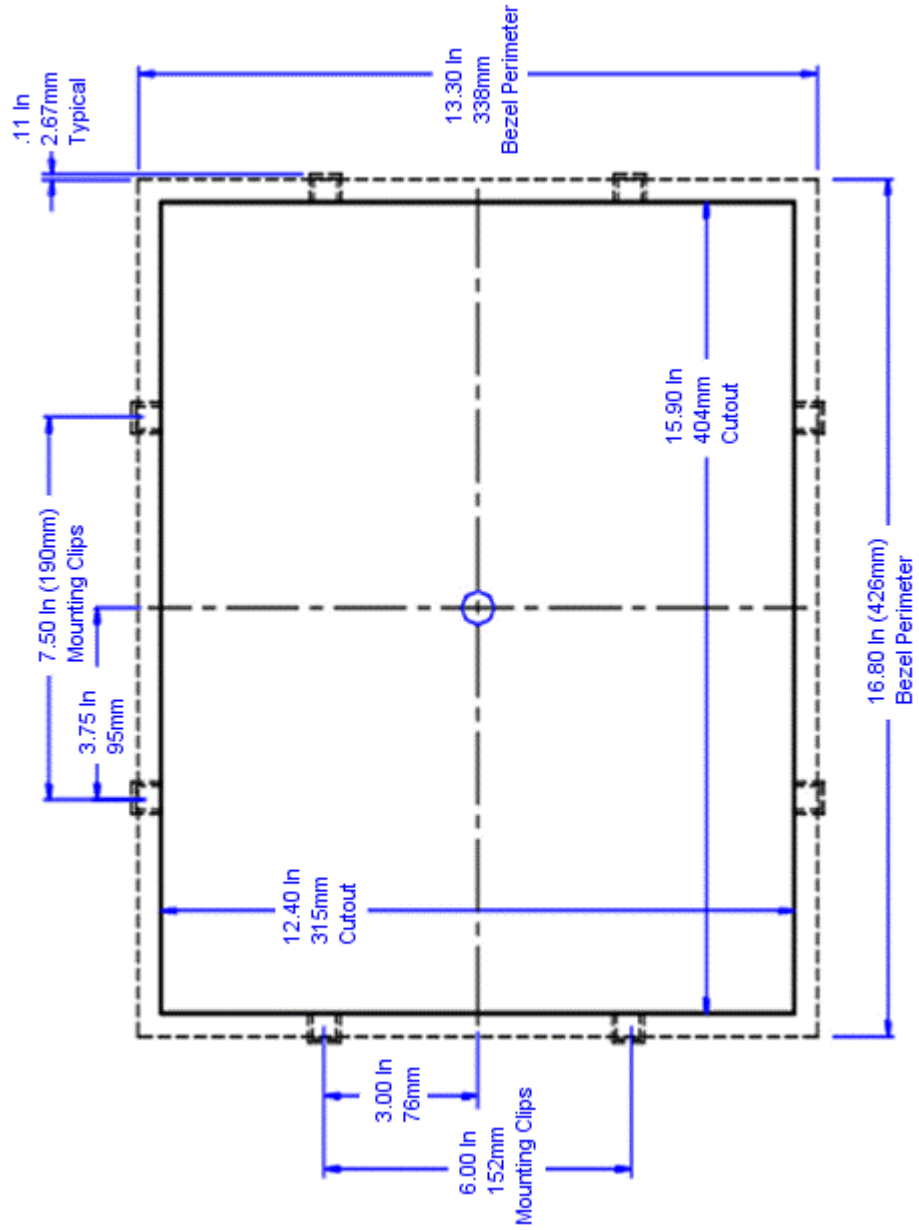

Model: PS10-3/PC10-3

Model: PS10-4/PC10-4

To access the complete CAD drawings and 3D models from the CD, complete the following steps:

1. Insert the Industrial PC Drivers and Utilities CD (DCD-1000) into your CD Rom drive if it isn't already in the CD ROM drive.

Note <SrcDir> is the drive where the CD is located. **File** represents the PowerStation drawing that you need.

2. Select <SrcDir>\Documentation\CAD Files\File.

Front View: Monitor

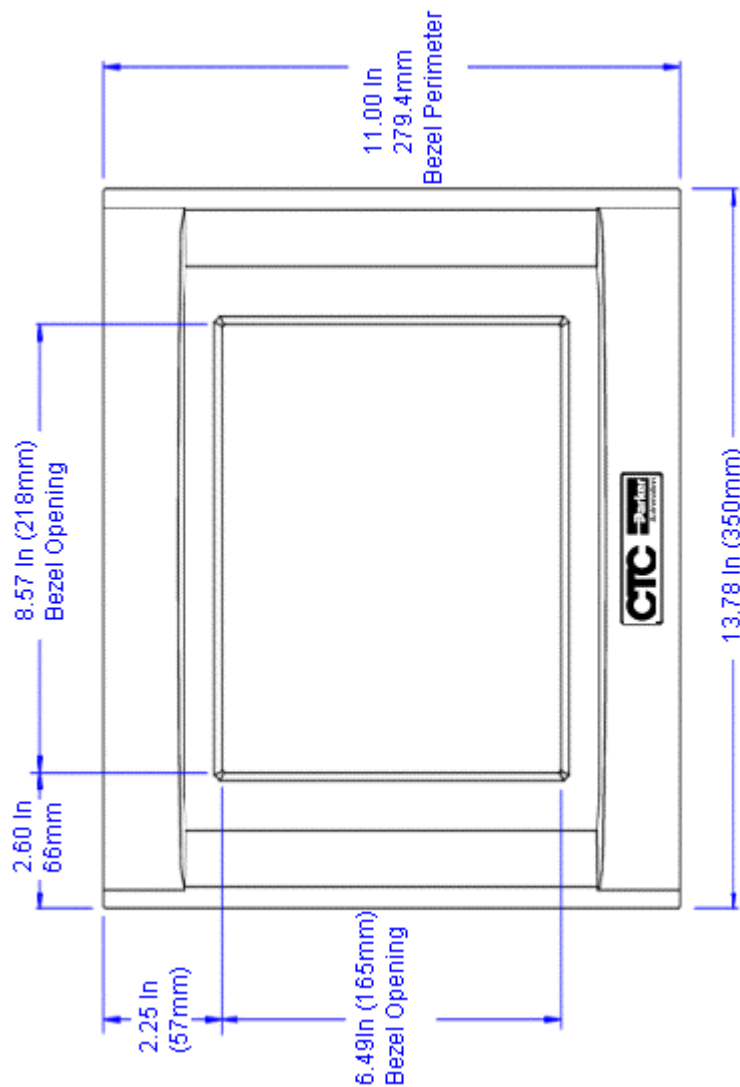

Left Side View: Components

(Model: PS10-3/PC10-3)

(Model: PS10-4/PC10-4)

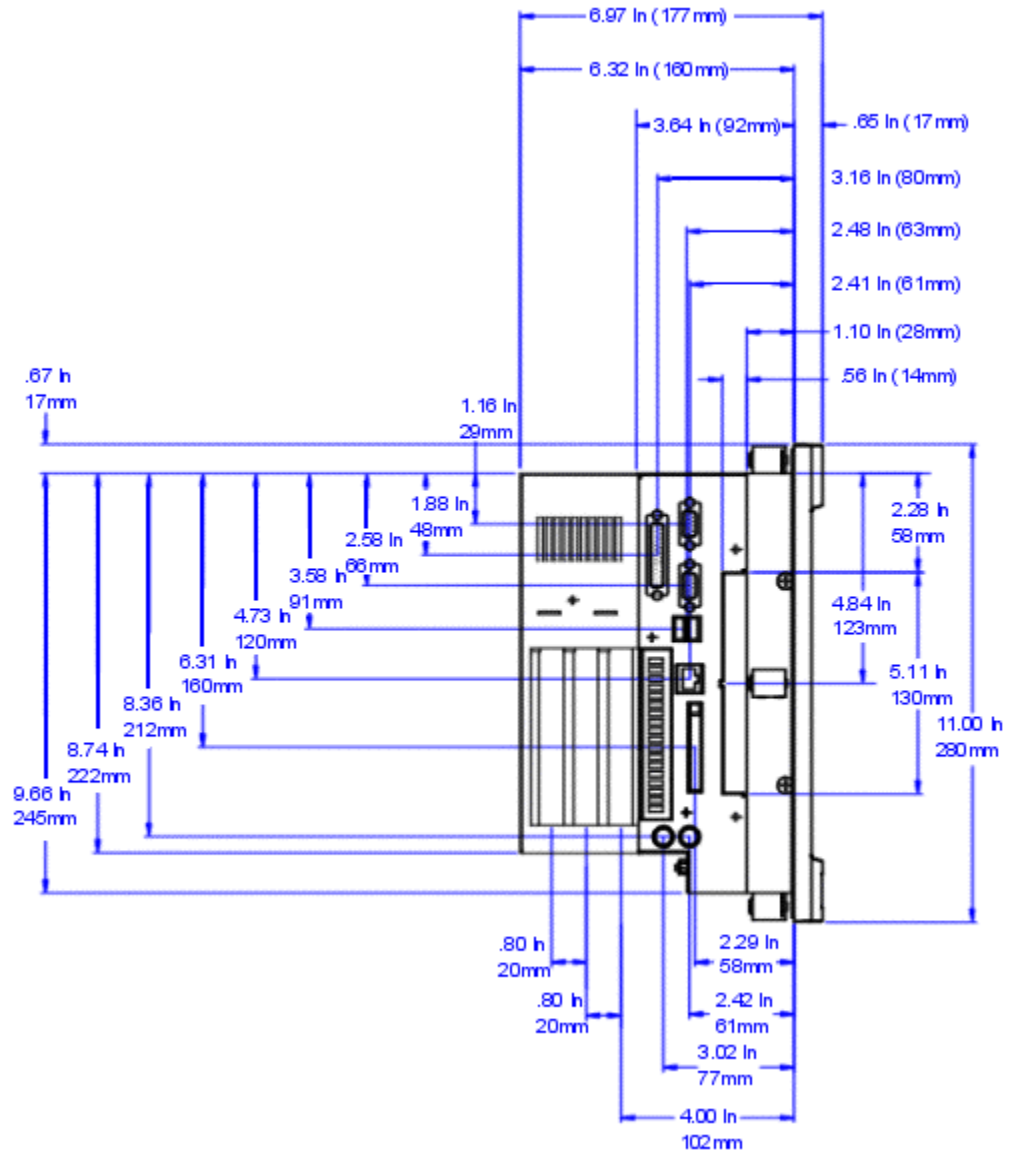

Back View: Components

(Model: PS10-3/PC10-3)

(Model: PS10-4/PC10-4)

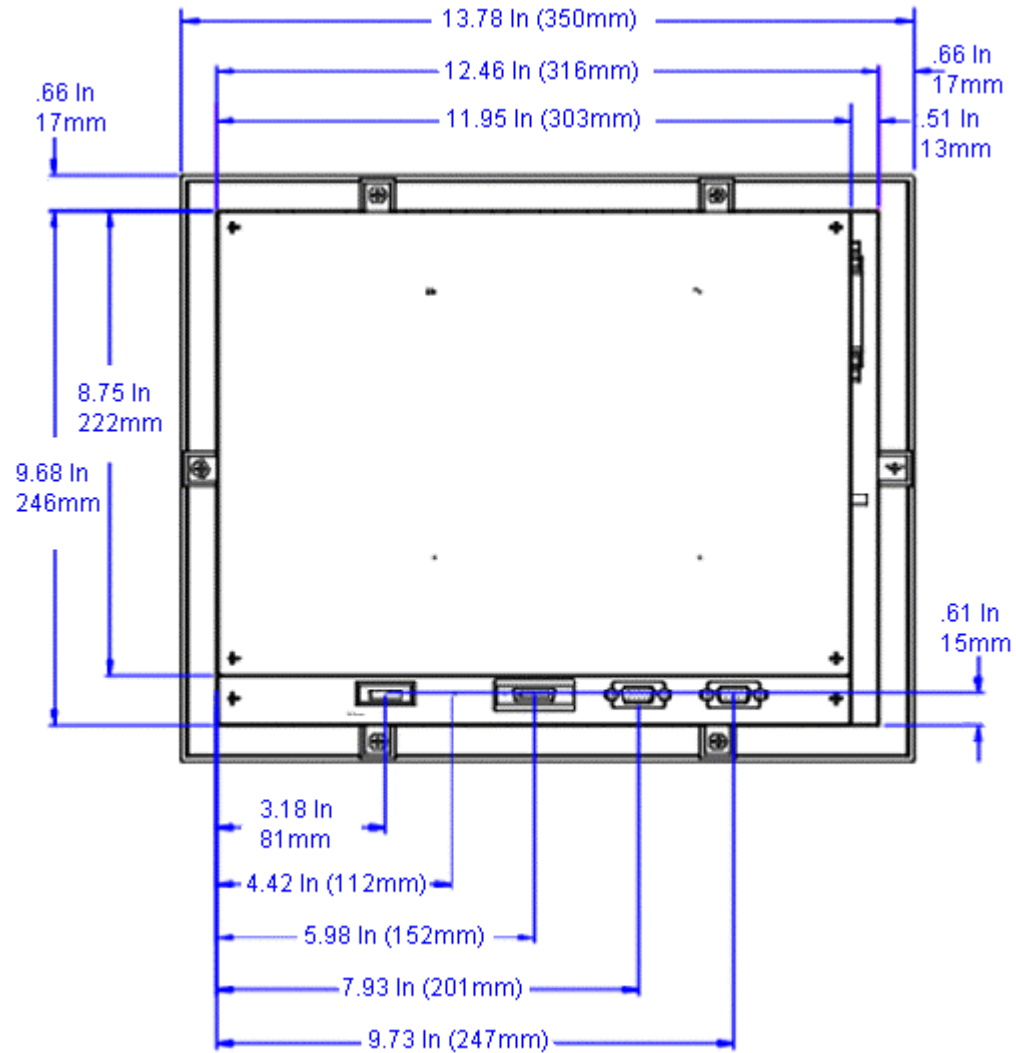

Cutout

(Model: PS10-3/PC10-3)

(Model: PS10-4/PC10-4)

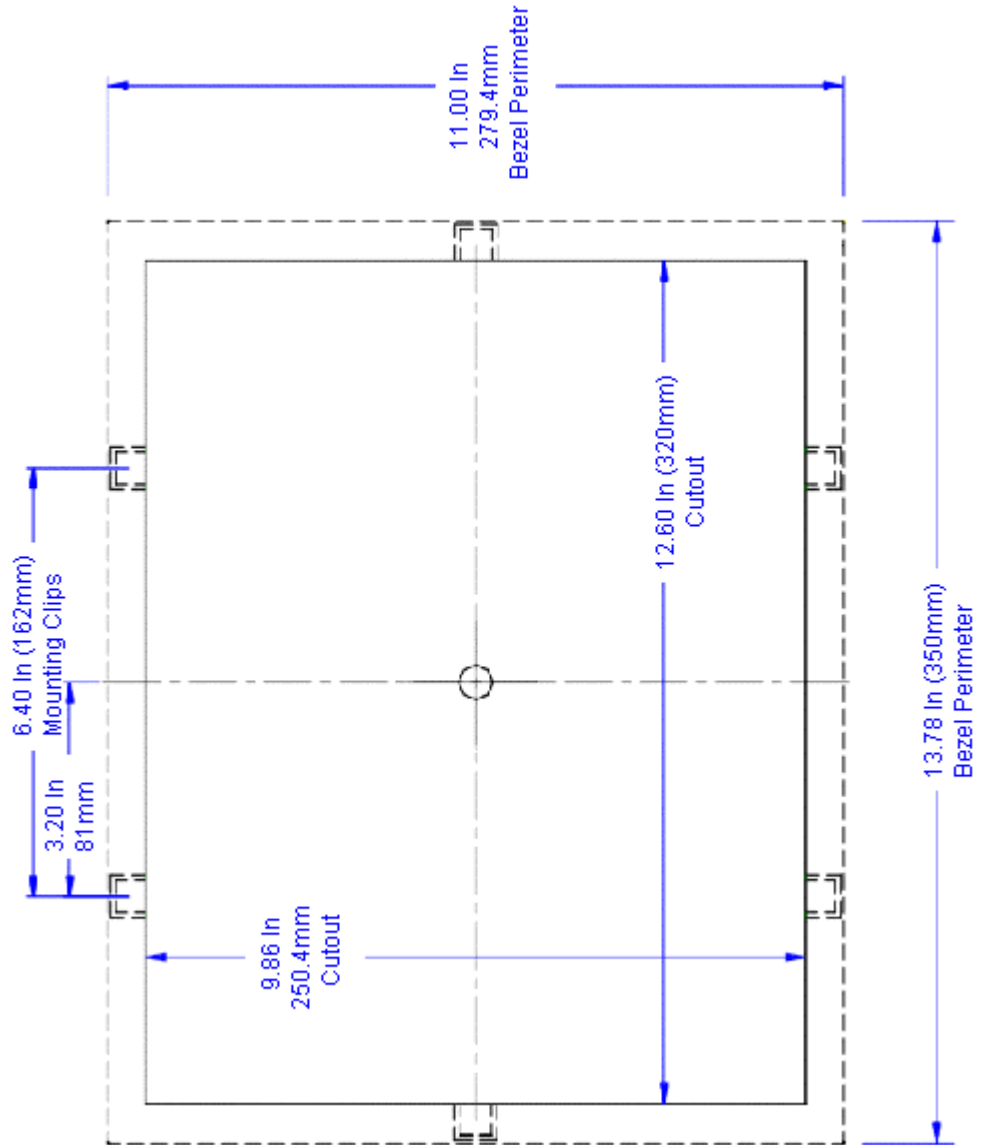

Model: PS12-3/PC12-3

Model: PS12-4/PC12-4

To access the complete CAD drawings and 3D models from the CD, complete the following steps:

1. Insert the Industrial PC Drivers and Utilities CD (DCD-1000) into your CD Rom drive if it isn't already in the CD ROM drive.

Note <SrcDir> is the drive where the CD is located. **File** represents the PowerStation drawing that you need.

2. Select <SrcDir>\Documentation\CAD Files\File.

Front View: Monitor

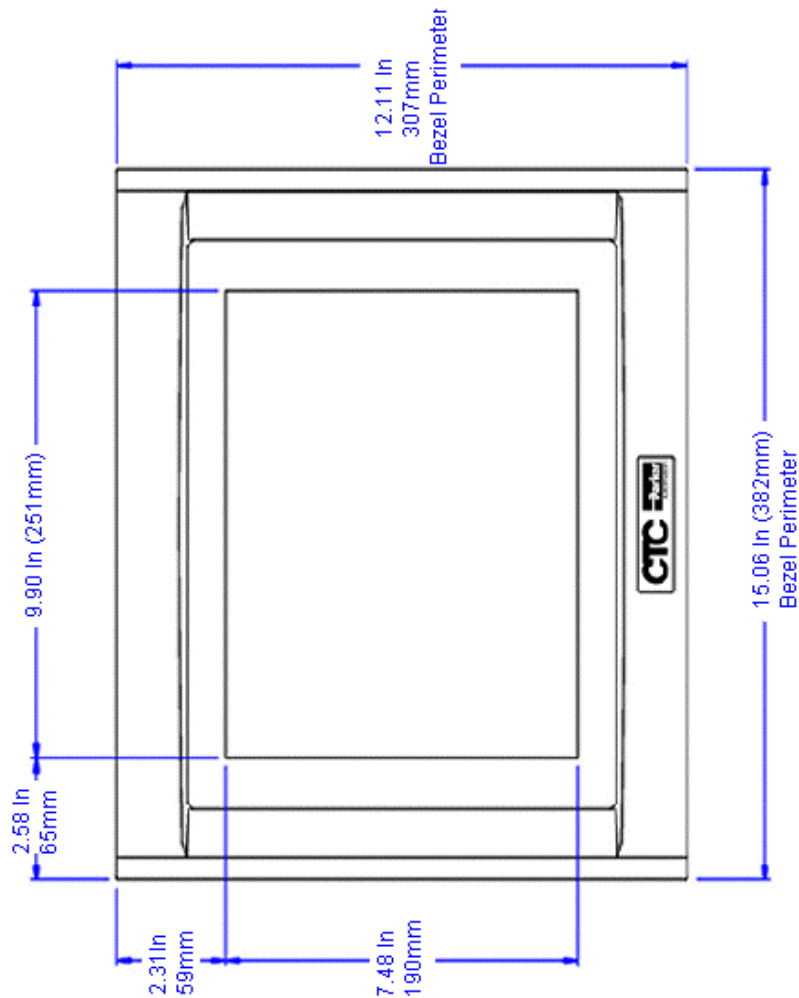

Left Side View: Components

(Model: PS12-3/PC12-3)

(Model: PS12-4/PC12-4)

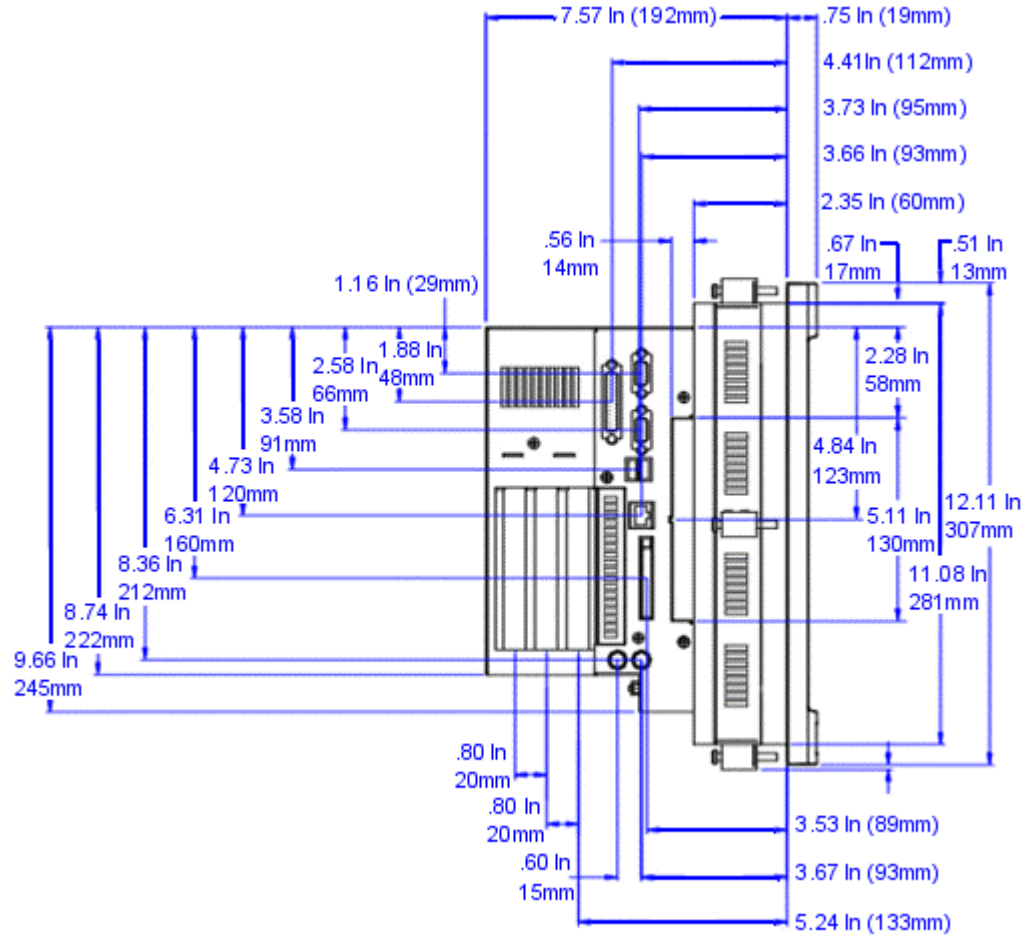

Back View: Components

(Model: PS12-3/PC12-3)

(Model: PS12-4/PC12-4)

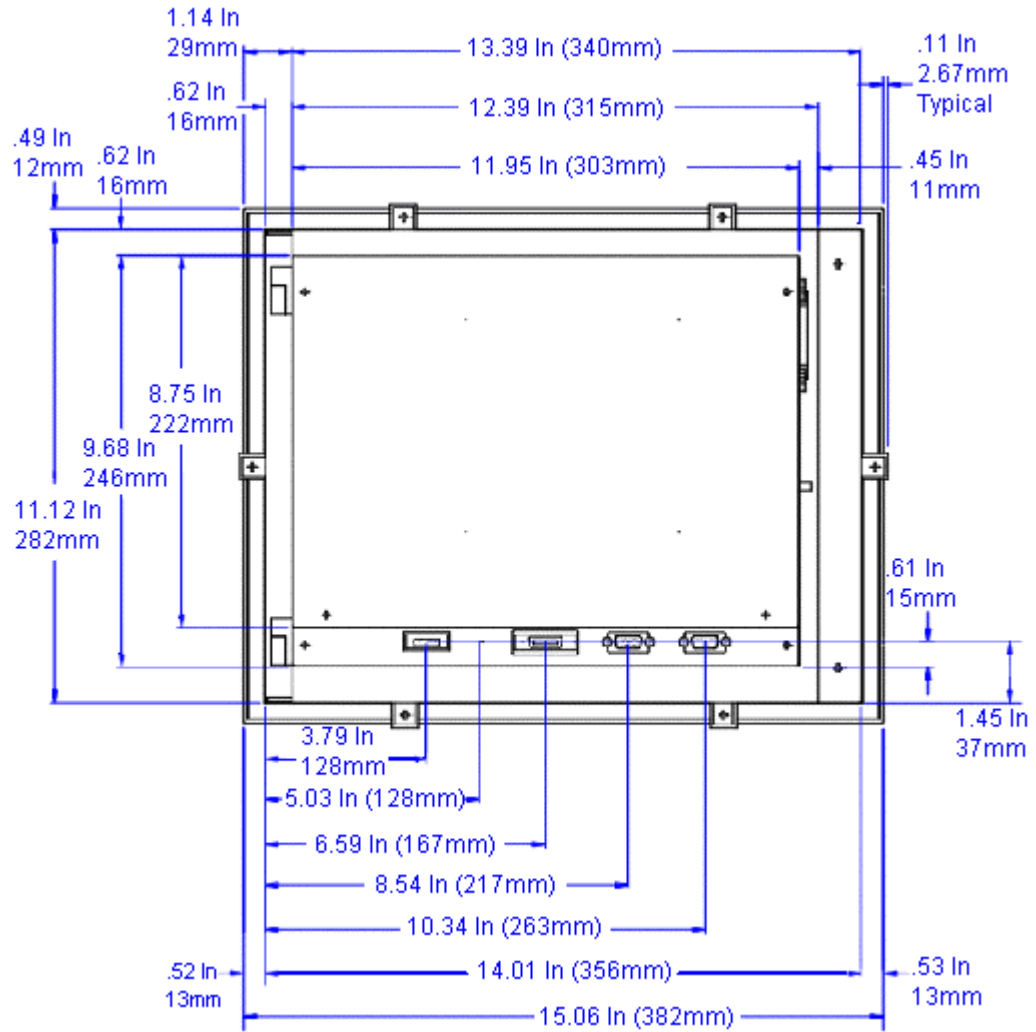

Cutout

(Model: PS12-3/PC12-3)

(Model: PS12-4/PC12-4)

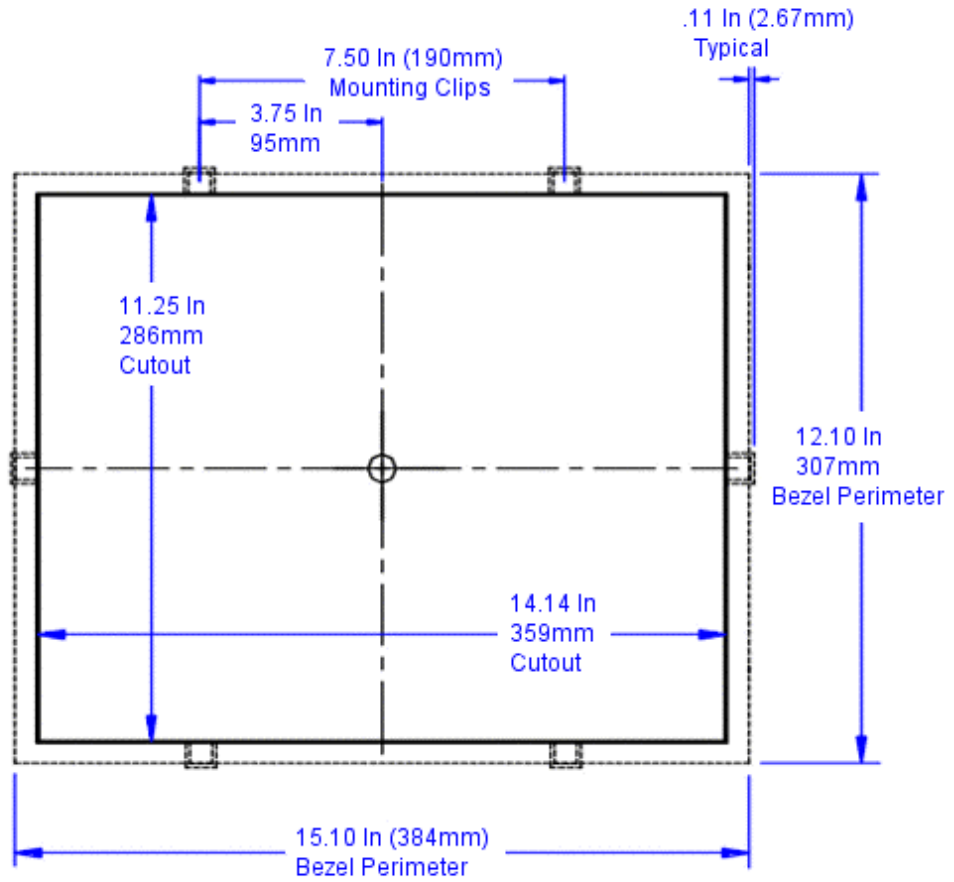

Model: PS15-3/PC15-3

Model: PS15-4/PC15-4

To access the complete CAD drawings and 3D models from the CD, complete the following steps:

1. Insert the Industrial PC Drivers and Utilities CD (DCD-1000) into your CD Rom drive if it isn't already in the CD ROM drive.

Note <SrcDir> is the drive where the CD is located. **File** represents the PowerStation drawing that you need.

2. Select <SrcDir>\Documentation\CAD Files\File.

Front View: Monitor

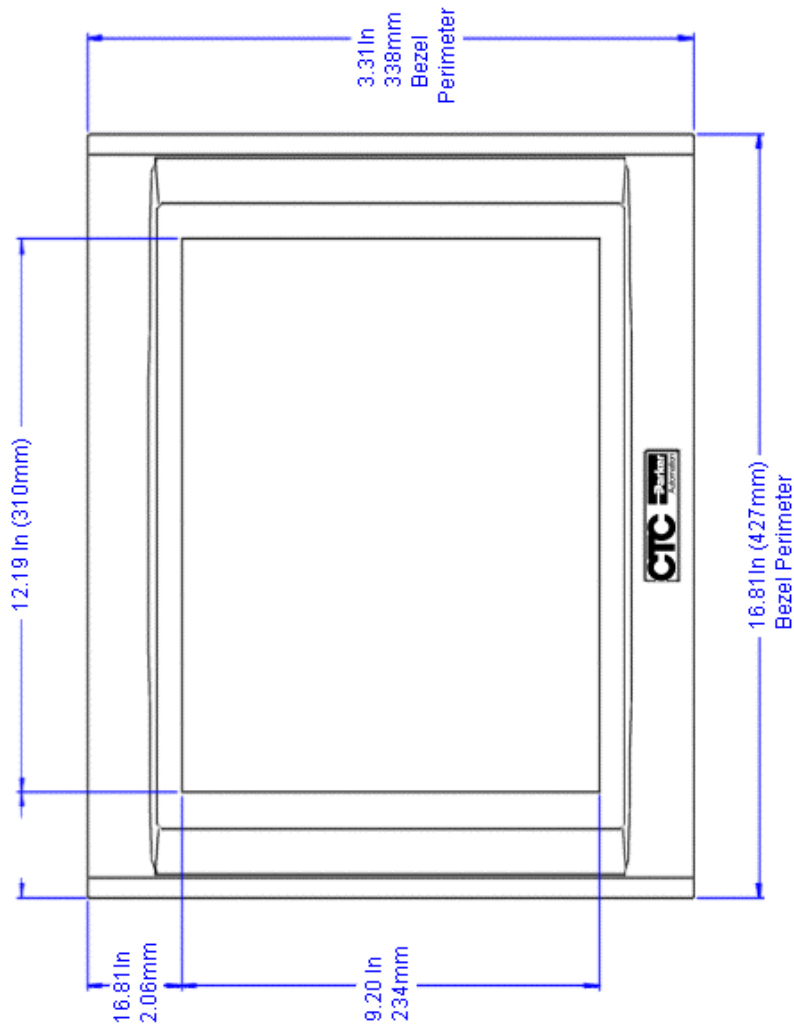

Left Side View: Components

(Model: PS15-3/PC15-3)

(Model: PS15-4/PC15-4)

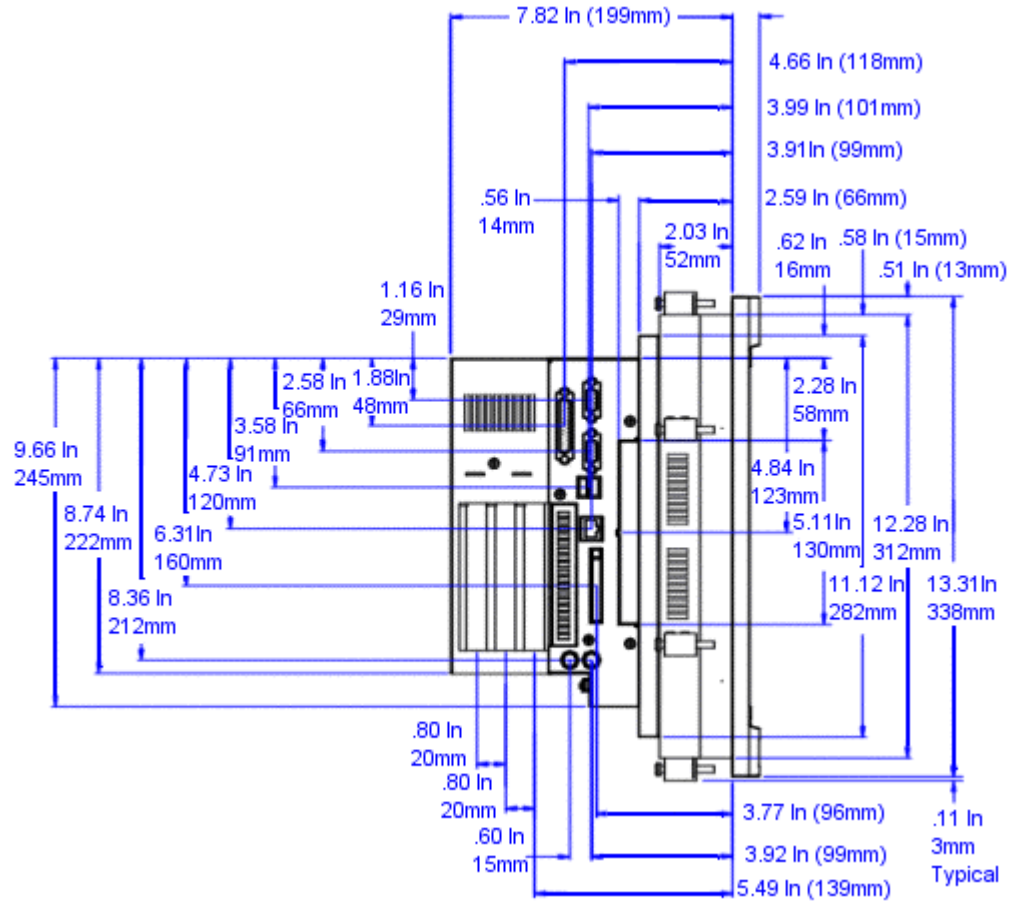

Back View: Components

(Model: PS15-3/PC15-3)

(Model: PS15-4/PC15-4)

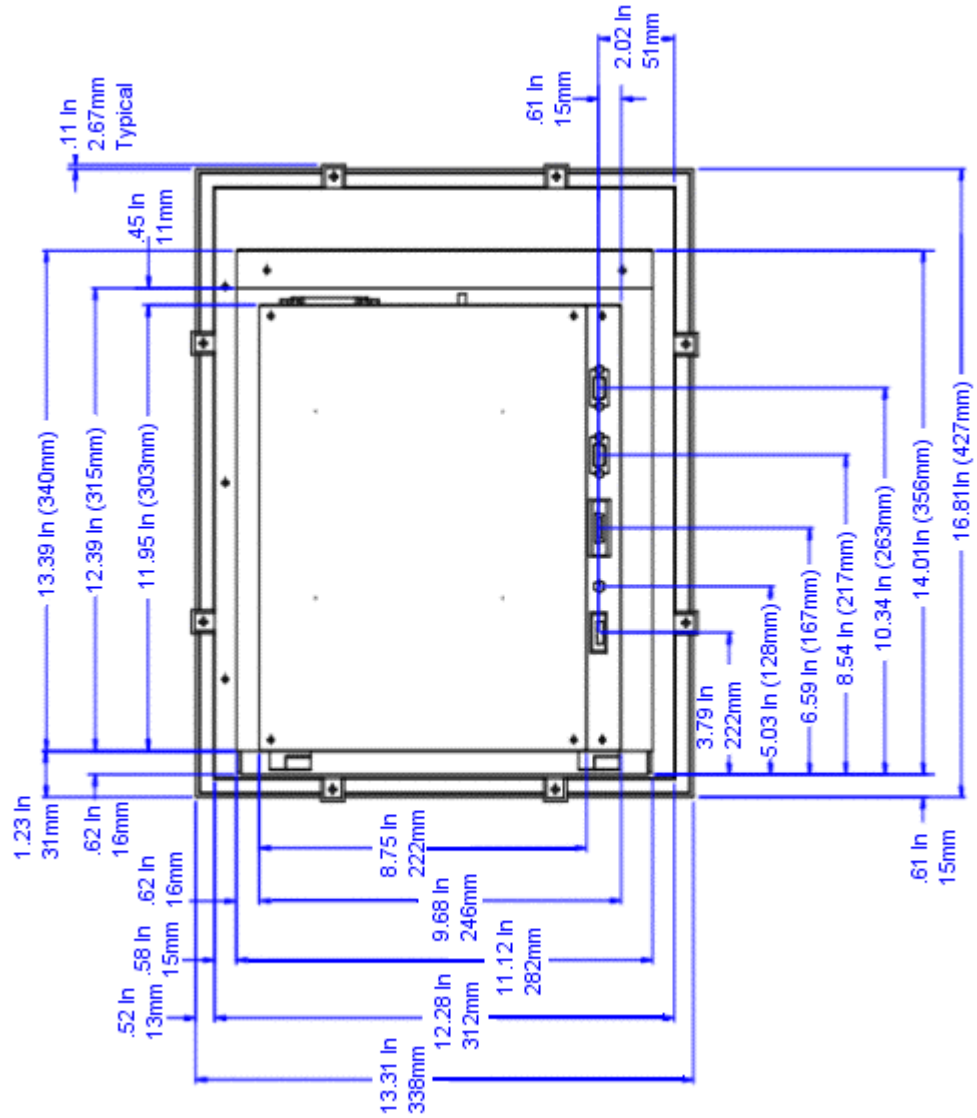

Model: RS00-2/RC00-2

To access the complete CAD drawings and 3D models from the CD, complete the following steps:

1. Insert the Industrial PC Drivers and Utilities CD (DCD-1000) into your CD Rom drive if it isn't already in the CD ROM drive.

Note <SrcDir> is the drive where the CD is located. **File** represents the PowerStation drawing that you need.

2. Select <SrcDir>\Documentation\CAD Files\File.

Left Side View: Components

(Model: RS00-2/RC00-2)

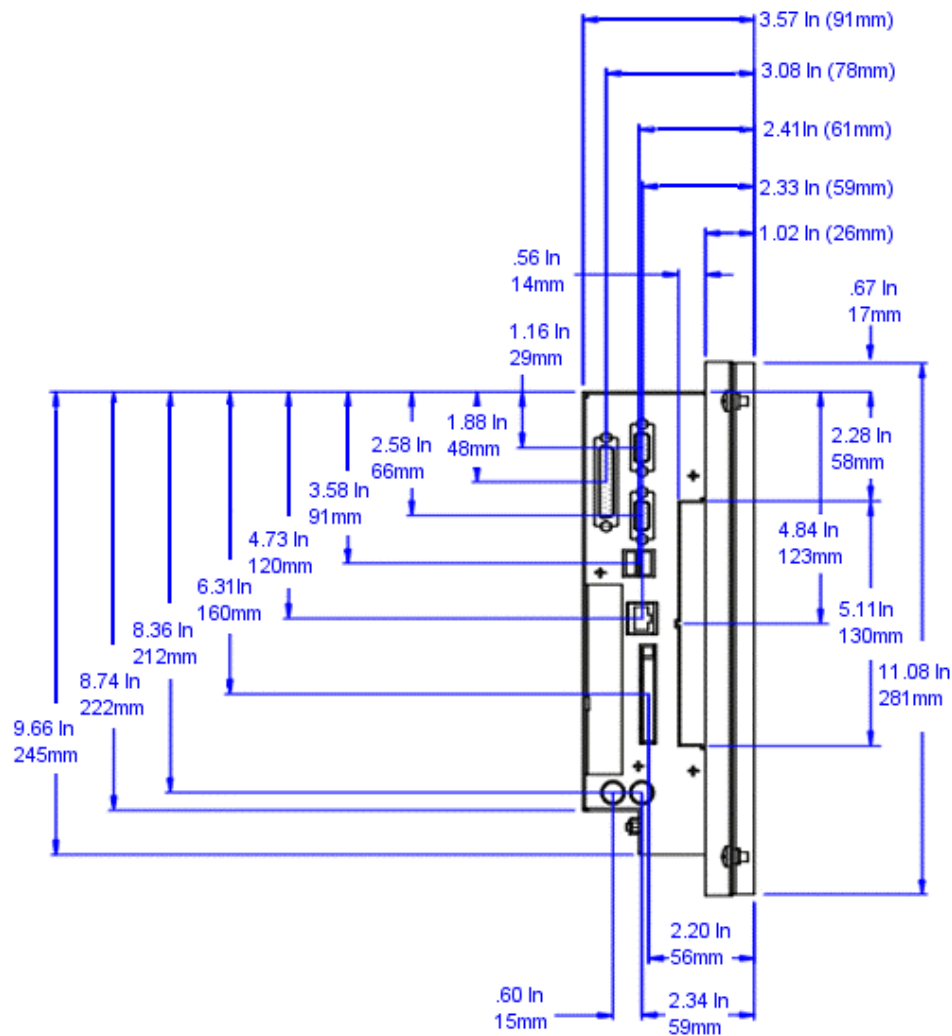

Back View: Components

(Model: RS00-2/RC00-2)

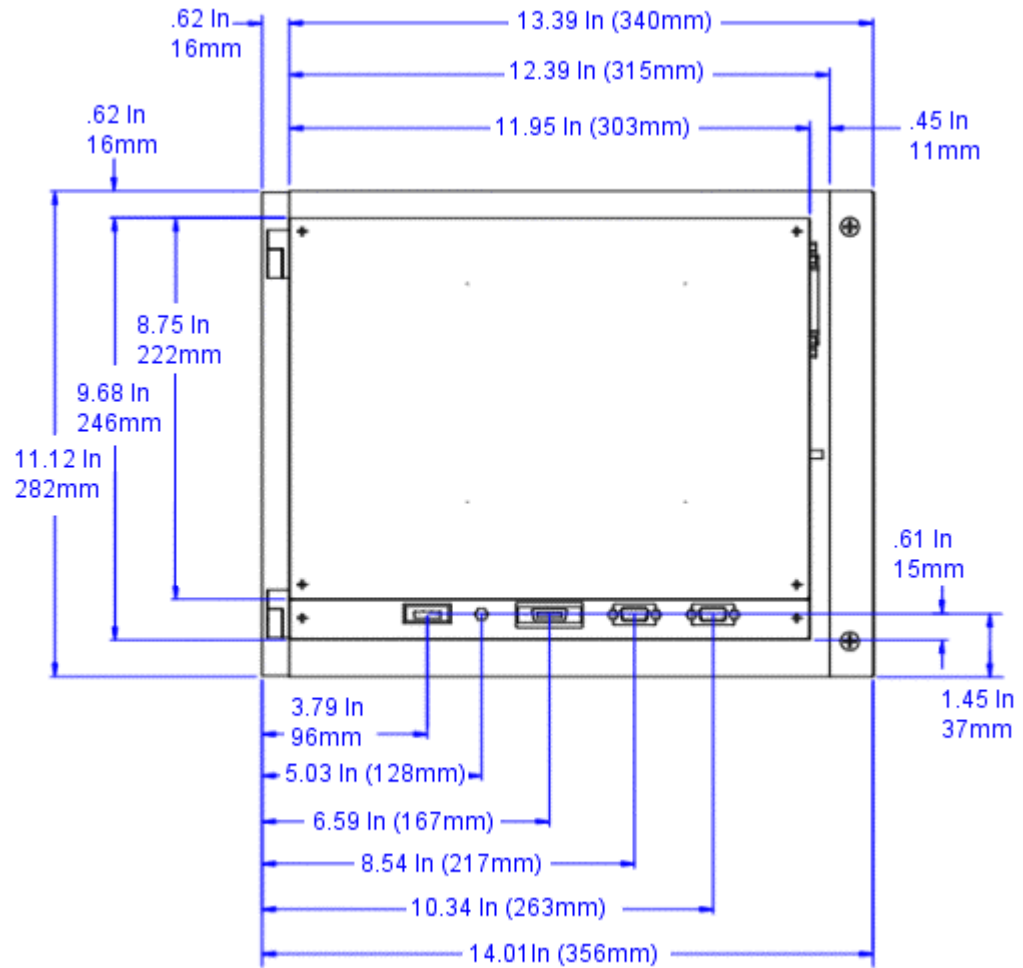

Model: RS00-3/RC00-3

Model: RS00-4/RC00-4

To access the complete CAD drawings and 3D models from the CD, complete the following steps:

1. Insert the Industrial PC Drivers and Utilities CD (DCD-1000) into your CD Rom drive if it isn't already in the CD ROM drive.

Note <SrcDir> is the drive where the CD is located. **File** represents the PowerStation drawing that you need.

2. Select <SrcDir>\Documentation\CAD Files\File.

Left Side View: Components

(Model: RS00-3/RC00-3)

(Model: RS00-4/RC00-4)

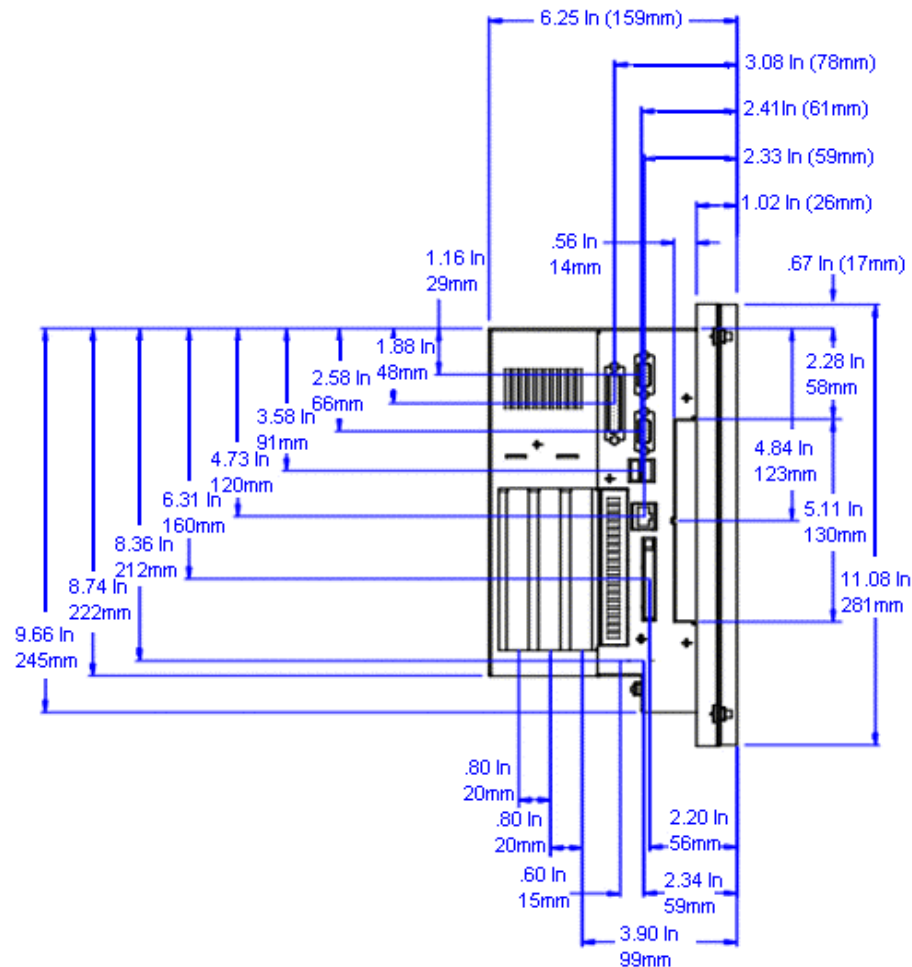

Back View: Components

(Model: RS00-3/RC00-3)

(Model: RS00-4/RC00-4)

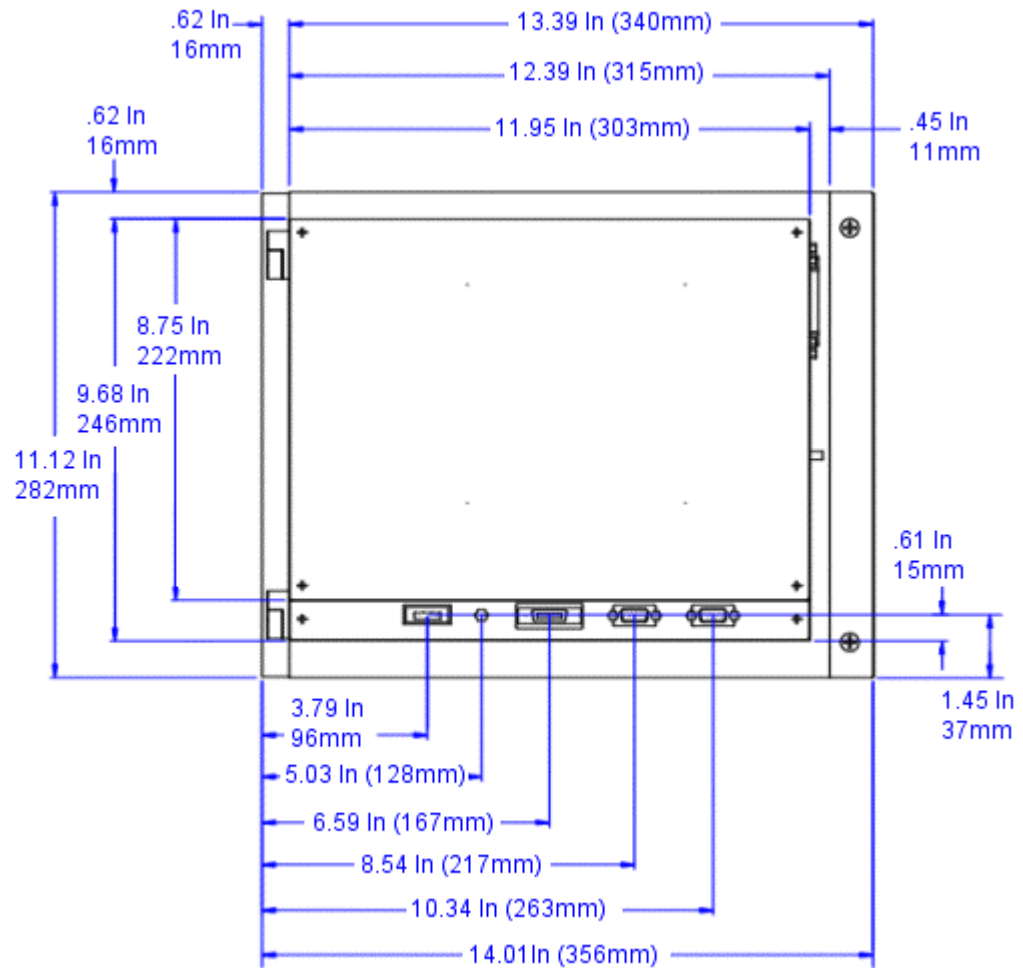

Cutout

(Model: RS00-3/RC00-3)

(Model: RS00-4/RC00-4)

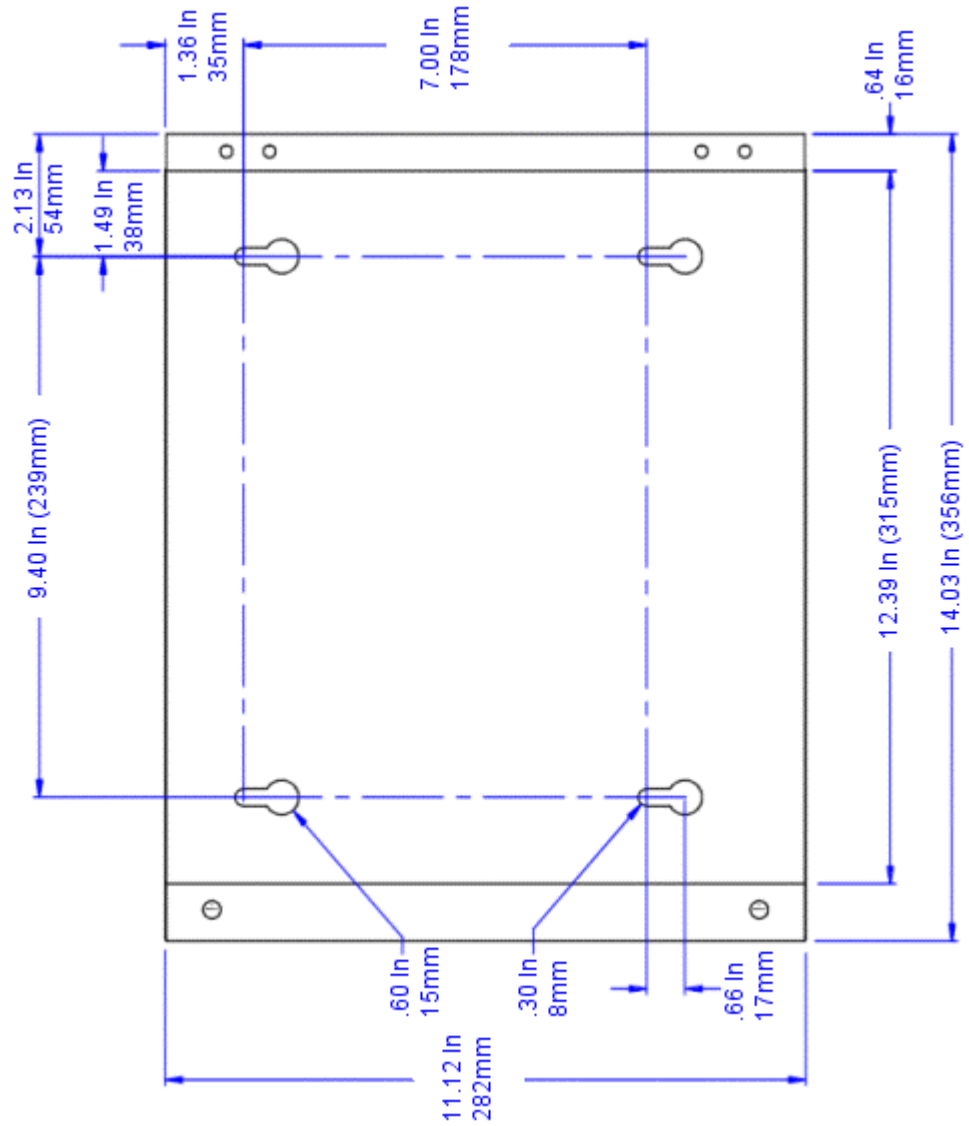

INDEX

A

Adapter cards, 69
Adding Expansion Cards, 69
Agency Approvals, 96
Application Engineering Services, 6
Autoexec.bat Files, 78

B

Backlight bulbs, 2, 65
Battery, 27, 65
BIOS, 15, 16, 32, 40, 43, 44, 45, 77, 89, 90
Brightness, 45
Bus interfaces, 14

C

CD-ROM, 4, 10, 17, 18, 19, 21, 37, 38, 46, 47, 48, 49, 51, 54, 55, 56, 59, 65, 79, 81, 88, 93
CF, 10, 14, 17, 18, 19, 21, 33, 38, 46, 57, 58, 59, 71, 73, 74, 77, 88
Class I, Division 2 Guidelines, 36
Cleaning the Display Screen, 60
CMOS settings, 71, 74
COM1, 10, 22, 23, 31, 73
COM2, 10, 14, 22, 23, 31, 71, 72
COM3, 10, 22, 23, 31, 40
Compact Flash, 4, 10, 17, 18, 21, 33, 43, 46, 59, 77, 88, 93
Config.sys Files, 80
Configurable jumpers, 14
Configuring Serial Ports, 44
Connecting the RS/RC Unit to a Monitor, 40
Contrast, 45
CPU, 9, 14, 15, 18, 23, 27, 28, 29, 30, 32, 71, 76, 88

Cutout Height, 38
Cutout Width, 38

D

Dimensional Drawings, 2, 37, 39, 97
Display Specifications, 92
displays, 2, 10, 16, 17, 26, 28, 29, 75, 92
Displays, 17, 83
Drive Functions, 21
Drives, 17, 37, 38

E

Electrical Guidelines, 36
Electrical Specifications, 94
Enclosure Guidelines, 37
Environmental Guidelines, 36
Environmental Specifications, 93
EPROM, 16, 90
ESD Precautions, 65
Ethernet port, 10, 14, 21, 38, 71, 72, 75, 85, 88
Ethernet Port, 25
Expansion slots, 10, 89, 94
Expansion Slots, 29, 30

F

faceplate, 36, 95
Faceplate Chemical Resistance, 95
FLASH memory, 15
Floppy disk drive, 65
Floppy Drive, 19, 20
Fuse, 27, 65, 94

G

Glossary of Terms, 4

H

Hard disk drive, 17, 65

I

I/O addresses, 9, 30, 85
Industrial PC Drivers and Utilities CD, 13, 46,
55, 98, 102, 106, 110, 114, 118, 122, 125
Internal Temperatures, 28
IRQ, 31, 32, 51, 52, 53, 62, 70, 71, 78, 84, 89
IRQs, 30, 31
ISO Symbols, 3

J

Jumper Settings, 51, 71

L

Lithium, 27

M

MachineShop Installation CD, 13, 56, 57, 59
Memory, 32, 33, 69, 80, 88
Monitor Size, 38
Mounting the System, 38
MS-DOS, 13, 29, 41, 42, 50, 57, 59, 60, 61, 62,
63, 76, 77, 80, 83, 85, 91
MS-DOS 6.22 and Utilities Installation Disk, 13
Multiboot Systems, 42

N

null modem, 24

O

Opening and Closing the System, 66

P

parallel port, 16, 21, 25, 88
Parallel port, 10, 30, 31
Parallel Port, 21, 25
Peripheral Devices, 28, 85
Physical Specifications, 88
Pinout data, 25, 26
Power Supply, 27, 90
PowerSmart, 4, 10, 28, 29, 47, 48, 55, 56, 75,
81, 82, 83, 90
PowerStation Start Disk, 13, 58, 78
Problems when starting, 75
Problems with peripheral devices, 75

Processor, 14, 88
Product Support Program (PSP), 7
PS/2 ports, 10, 21, 25, 88

R

RAM, 15, 75, 76
Recalibrating the Touchscreen, 62
Reconfiguring the Touchscreen Driver, 60
Reconfiguring under Windows, 61
Reinstalling drivers, 58
Reinstalling MachineShop, 56
Reinstalling the MachineShop Shell, 57
Replacement components, 65
Replacing Components, 65
Resetting Disk Boot Priority, 44
reverse polarity, 27
RS 232, 23
RS232, 73, 88
RS-232, 23, 24
RS422, 72, 73
RS-422, 23, 24
RS485, 72
RS-485, 23, 24, 72
Runtime, 4, 33, 57

S

SDRAM, 32, 33, 65, 76, 87, 88, 89, 91
Selecting a Location, 36
serial ports, 10, 16, 21, 22, 24, 38, 44, 73, 88
Serial Ports, 22, 44
system parameters, 29

T

Technical Support, 1, 2, 5, 46, 57, 65, 75, 82, 83,
84
Temperature Guidelines, 37
Testing Specifications, 94
Touchscreen, 4, 60, 64, 65, 84, 89
Training, 5, 6
Troubleshooting, 2, 5, 43, 75

U

USB ports, 10, 21, 26, 38, 88

V

Video port, 10, 88
Video Port, 26

W

Warranty, 2

watchdog timer, 28, 90

Watchdog timer, 10, 30

Win NT 4.0 Emergency Recovery Disk, 13, 47,

48

Windows 2000, 13, 32, 47, 48, 52, 53, 54, 91

Windows 2000 Emergency Recovery Disk, 13,
47

Windows 98, 47, 48, 49, 57, 91

Windows NT, 13, 41, 42, 47, 48, 49, 55, 91

